

# **DIGITAL I/O FOR RASPBERRY PI SELECTION GUIDE**

# DIGITAL I/O FOR RASPBERRY PI SELECTION GUIDE

Form 2208-170413—April 2017

**OPTO 22**  
**Automation made simple.**

43044 Business Park Drive • Temecula • CA 92590-3614  
Phone: 800-321-OPTO (6786) or 951-695-3000  
Fax: 800-832-OPTO (6786) or 951-695-2712  
[www.opto22.com](http://www.opto22.com)

**Product Support Services**

800-TEK-OPTO (835-6786) or 951-695-3080  
Fax: 951-695-3017  
Email: [support@opto22.com](mailto:support@opto22.com)  
Web: [support.opto22.com](http://support.opto22.com)

Digital I/O for Raspberry Pi Selection Guide

Form 2208-170413—April 2017

Copyright © 2016–2017 Opto 22.

All rights reserved.

Printed in the United States of America.

The information in this manual has been checked carefully and is believed to be accurate; however, Opto 22 assumes no responsibility for possible inaccuracies or omissions. Specifications are subject to change without notice.

Opto 22 warrants all of its products to be free from defects in material or workmanship for 30 months from the manufacturing date code. This warranty is limited to the original cost of the unit only and does not cover installation, labor, or any other contingent costs. Opto 22 I/O modules and solid-state relays with date codes of 1/96 or newer are guaranteed for life. This lifetime warranty excludes reed relay, SNAP serial communication modules, SNAP PID modules, and modules that contain mechanical contacts or switches. Opto 22 does not warrant any product, components, or parts not manufactured by Opto 22; for these items, the warranty from the original manufacturer applies. Refer to Opto 22 form 1042 for complete warranty information.

---

Wired+Wireless controllers and brains are licensed under one or more of the following patents: U.S. Patent No(s). 5282222, RE37802, 6963617; Canadian Patent No. 2064975; European Patent No. 1142245; French Patent No. 1142245; British Patent No. 1142245; Japanese Patent No. 2002535925A; German Patent No. 60011224.

Opto 22 FactoryFloor, *groov*, Optomux, and Pamux are registered trademarks of Opto 22. Generation 4, *groov* Server, ioControl, ioDisplay, ioManager, ioProject, ioUtilities, *mistic*, Nvio, Nvio.net Web Portal, OptoConnect, OptoControl, OptoDataLink, OptoDisplay, OptoEMU, OptoEMU Sensor, OptoEMU Server, OptoOPCServer, OptoScript, OptoServer, OptoTerminal, OptoUtilities, PAC Control, PAC Display, PAC Manager, PAC Project, PAC Project Basic, PAC Project Professional, SNAP Ethernet I/O, SNAP I/O, SNAP OEM I/O, SNAP PAC System, SNAP Simple I/O, SNAP Ultimate I/O, and Wired+Wireless are trademarks of Opto 22.

ActiveX, JScript, Microsoft, MS-DOS, VBScript, Visual Basic, Visual C++, Windows, and Windows Vista are either registered trademarks or trademarks of Microsoft Corporation in the United States and other countries. Linux is a registered trademark of Linus Torvalds. ARCNET is a registered trademark of Datapoint Corporation. Modbus is a registered trademark of Schneider Electric, licensed to the Modbus Organization, Inc. Wiegand is a registered trademark of Sensor Engineering Corporation. Allen-Bradley, CompactLogix, ControlLogix, MicroLogix, SLC, and RSLogix are either registered trademarks or trademarks of Rockwell Automation. CIP and EtherNet/IP are trademarks of ODVA. Raspberry Pi is a trademark of the Raspberry Pi Foundation.

*groov* includes software developed by the OpenSSL Project for use in the OpenSSL Toolkit. (<http://www.openssl.org>)

All other brand or product names are trademarks or registered trademarks of their respective companies or organizations.

Opto 22

Automation Made Simple.

# Table of Contents

<b>Chapter 1: Welcome</b> .....	<b>1</b>
Introduction .....	1
What You Need .....	2
Digital I/O Carrier Board for Raspberry Pi .....	2
Choose your I/O Family .....	3
G4 I/O .....	3
SNAP I/O .....	3
What's in this Book .....	3
For Help .....	3
<b>Chapter 2: G4 Digital I/O</b> .....	<b>5</b>
G4 with the Raspberry Pi and Digital I/O Carrier Board .....	5
Choose a G4 Mounting Rack .....	6
A Note on Fuses .....	6
Choose Your Rack .....	6
G4PB8H Mounting Rack .....	7
Description .....	7
Specifications .....	7
Dimensions—G4PB8H .....	7
Connections—G4PB8H .....	8
G4PB16H Mounting Rack .....	8
Description .....	8
Specifications .....	8
Dimensions—G4PB16H .....	9
Connections—G4PB16H .....	9
Choose your G4 I/O Modules .....	10
Features .....	10
Choose Your Module .....	10
G4 Digital DC Input Modules .....	11
Description .....	11
Specifications—DC Input Modules .....	11
Specifications—DC Input Module with manual/auto switch .....	12
Dimensions—DC Input Modules .....	13
Schematics—DC Input Modules .....	13
G4 Digital AC Input Modules .....	14

Description .....	14
Specifications—AC Input Modules .....	14
Dimensions—AC Input Modules .....	15
Schematics—AC Input Modules .....	15
G4 Digital Input Test Module .....	16
Description .....	16
Specifications—Digital Input Test Module .....	16
Dimensions and Schematics—Digital Input Test Module .....	16
G4 Digital DC Output Modules .....	17
Description .....	17
Specifications—DC Output Modules .....	17
Dimensions—DC Output Modules .....	18
Schematics—DC Output Modules .....	18
G4 Digital AC Output Modules .....	19
Description .....	19
Specifications—AC Output Modules .....	19
Dimensions—AC Output Modules .....	20
Schematics—AC Output Modules .....	20
G4 Digital Output Test Module .....	21
Description .....	21
Specifications—Output Test Module .....	21
Dimensions and Schematics—Output Test Module .....	21
G4 I/O Field Wiring .....	22
Input Modules Using DC Field Voltages .....	22
Input Modules Using AC Field Voltages .....	22
Output Modules Using DC Field Voltages .....	23
Output Modules Using AC Field Voltages .....	23

### **Chapter 3: SNAP Digital I/O .....25**

SNAP with the Raspberry Pi and Digital I/O Carrier Board .....	25
SNAP Mounting Rack .....	26
Specifications .....	26
Choose your SNAP I/O modules .....	27
Features .....	27
Choose Your Module .....	27
SNAP Digital Input Modules .....	28
Specifications: SNAP Digital Input Modules .....	29
Specifications: SNAP Digital Input Modules (continued) .....	30
SNAP Dry Contact Modules .....	31
Specifications: SNAP Dry Contact Modules .....	31
SNAP Digital Output Modules .....	32
Specifications: SNAP AC Output Modules .....	33
Specifications: SNAP DC Output Modules .....	34
Specifications: SNAP DC Output Modules (continued) .....	35
SNAP Mechanical Power Relay Output Modules .....	36
Specifications: SNAP Mechanical Power Relay Output Modules .....	37
Wiring Diagrams .....	38
Wiring: Most SNAP Digital Input and Output Modules (except Dry Contact and Mechanical Power Relay Modules) .....	38
Wiring: Dry Contact Modules .....	39

---

Wiring: Mechanical Power Relay Modules .....	40
Dimensional Drawings .....	41
All SNAP Input Models Except MA .....	41
All SNAP Output Models Except MA and Mechanical Relays .....	42
All MA Models .....	43
All SNAP Mechanical Power Relay Output Modules .....	44
Bottom, All Models .....	45
<b>Chapter 4: Digital I/O Accessories .....</b>	<b>47</b>
Overview of Accessories .....	47
Power Supplies .....	47
Power Supplies for G4 .....	47
Power Supplies for SNAP .....	48
Fuses .....	49
G4 Fuses .....	49
SNAP Fuses .....	49
Jumper Straps .....	50
G4 Jumper Strap .....	50
SNAP Jumper Straps .....	50
<b>Chapter 5: Reading and Writing .....</b>	<b>53</b>
Overview .....	53
Mapping: GPIO Pins to SNAP I/O Modules .....	53
Mapping: GPIO Pins to G4 Modules .....	54
Mapping Overlay for Raspberry Pi .....	54



# 1: Welcome

## Introduction

Now you can safely and reliably sense and switch 5–60 VDC, 120 VAC, and 240 VAC loads with a Raspberry Pi®. Your Pi can switch industrial-level electrical loads far beyond the Pi's built in 3.3 VDC GPIO pins, so you can monitor and control electrical loads required for real-world devices like industrial motors, pumps, and sensors.

This Digital I/O System for Raspberry Pi is ideal for prototyping, proofs of concept, and environments in which an industrially hardened controller isn't required.

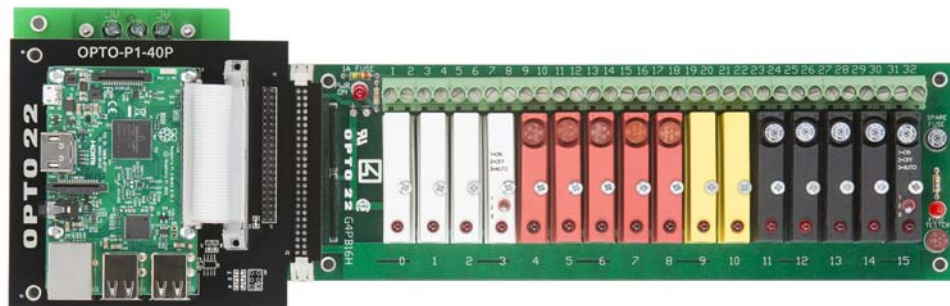

**Digital I/O System for Raspberry Pi**—This example shows a Pi, the Digital I/O Carrier Board, a PBSA industrial power supply, a G4 mounting rack, and 16 G4 digital I/O modules. All items are sold separately; build your system based on your application's requirements.



**Digital I/O System for Raspberry Pi**—This example shows a Pi, the Digital I/O Carrier Board, and a SNAP mounting rack with four 4-point SNAP digital I/O modules, totalling 16 I/O points. All items are sold separately.

## What You Need

- **Raspberry Pi**—Any model with a 40-pin GPIO header connector
- **Digital I/O Carrier Board for Raspberry Pi**—Provides a GPIO interface to connect your Pi to the digital I/O mounting rack.
- **I/O mounting rack**—Holds I/O modules.
- **Digital I/O modules**—Wired directly to field sensors and actuators, these input and output (I/O) modules from automation manufacturer Opto 22 have a long track record of reliable service worldwide.
- **Power supply**—The Pi can be powered from the rack or the rack from the Pi. An industrial quality rack power supply is recommended.

## Digital I/O Carrier Board for Raspberry Pi

Opto 22's Digital I/O Carrier Board for Raspberry Pi (part number [OPTO-P1-40P](#)) is the key part in the system. It connects your Pi to the digital I/O rack. The Carrier Board includes an interface cable and Pi board mounting standoffs.

Insert the Carrier Board's cable into your Pi's 40-pin GPIO connector, and snap the board onto a compatible Opto 22 I/O rack.

An auxiliary 40-pin connector on the Carrier Board supports HAT add-on boards using UART, SPI, or I2C.

Use your favorite Pi-supported programming language to read and write to up to 16 digital I/O points on the rack. Code samples and more programming information are available on [developer.opto22.com](http://developer.opto22.com).

The industrially hardened Carrier Board withstands temperatures of -20 to 70 °C (operating) or -40 to 85 °C (in storage) and relative humidity of 95% (non-condensing). It is CE approved and carries a warranty of 30 months from the date of manufacture.

See the [Digital I/O Carrier Board for Raspberry Pi](#) on our website.



**Digital I/O Carrier Board for Raspberry Pi**

## Choose your I/O Family

Once you have your Pi and your Carrier Board, just choose the I/O family most suited to your needs: G4 or SNAP.

*NOTE: If you prefer to use Quad Pak or G1 I/O digital modules, the CarrierBoard also supports the following racks: PB16HQ, PB4H, PB8H, and PB16H.*

### G4 I/O

G4 modules were first introduced in 1989 and are still manufactured today. G4 I/O modules have only 1 point per module for maximum flexibility. Most output modules are individually fused and include an LED to indicate status. Each output module can switch up to 3 A.

To choose your G4 rack and I/O, see [Chapter 2: G4 Digital I/O](#).

### SNAP I/O

SNAP I/O takes up less space with four points per module and costs less per point. Four LEDs are visible on the top of the module to indicate status for each of the four points. Most output modules can switch up to 0.75 A per point or a total of 3 A per module. If you need a higher current rating, SNAP-OMR6 modules can switch up to 6 A per point.

To choose your SNAP rack and I/O, see [Chapter 3: SNAP Digital I/O](#).

## What's in this Book

This *Digital I/O for Raspberry Pi Selection Guide* pulls together information on the digital I/O products you can use with your Raspberry Pi:

**Chapter 2: G4 Digital I/O**—Choose your G4 mounting rack and I/O. Includes detailed drawings, specifications, and wiring diagrams.

**Chapter 3: SNAP Digital I/O**—Choose your SNAP I/O and see drawings, specifications, and wiring diagrams.

**Chapter 4: Digital I/O Accessories**—Find power supplies, fuses, and jumper straps for G4 and SNAP.

**Chapter 5: Reading and Writing**—Includes pin mapping diagrams.

## For Help

If you have any questions about these digital I/O products for Raspberry Pi and cannot find the answers you need in this book or on our website, please contact Opto 22 Product Support. Technical support for all Opto 22 products is free. See contact information on the following page.

**Phone:** 800-TEK-OPTO (800-835-6786  
toll-free in the U.S. and Canada)  
951-695-3080  
Monday through Friday,  
7 a.m. to 5 p.m. Pacific Time

**Fax:** 951-695-3017

**Email:** [support@opto22.com](mailto:support@opto22.com)

**Opto 22 website:** [www.opto22.com](http://www.opto22.com)

*NOTE: Email messages and phone calls to Opto 22 Product Support are grouped together and answered in the order received.*

When calling for technical support, be prepared to provide a complete description of your hardware and operating system to the Product Support engineer. This information should include:

- Accessories installed
- Type of power supply
- Types of I/O modules and racks used
- Third-party devices installed
- Wiring for your system

# 2: G4 Digital I/O

## G4 with the Raspberry Pi and Digital I/O Carrier Board

Your G4 system—complete with the Pi, Carrier Board, G4 mounting rack and 8 G4 I/O modules—looks something like this:

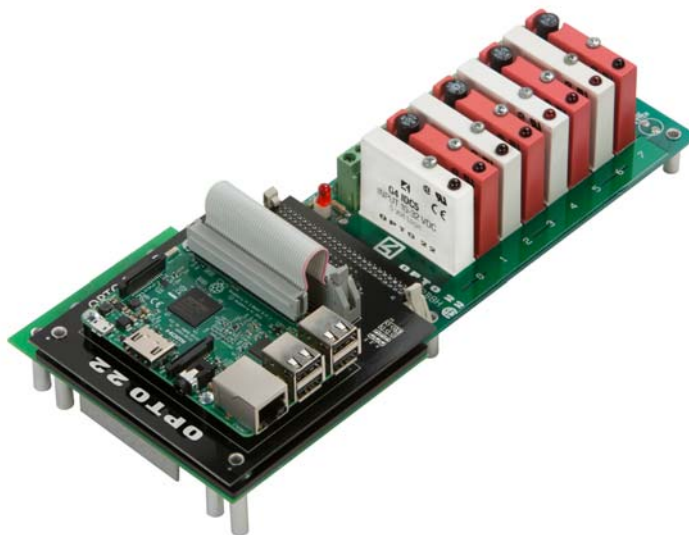

See the following pages for details on parts of the G4 system:

- [Choose a G4 Mounting Rack](#) page 6
- [Choose your G4 I/O Modules](#) page 10
- [Power supplies and other accessories](#) page 47

## Choose a G4 Mounting Rack

G4 digital I/O mounting racks hold 8 or 16 single-point I/O modules and include these features:

- Modules are securely attached with a threaded captive hold-down screw. Modules can be inserted and removed easily and quickly without disturbing field wiring.
- Spare fuse included for G4 output modules
- Barrier strips with screw terminals provide the field and mounting rack power connections.
- Uses a single 5 VDC power supply for control power (see [“Power Supplies” on page 47](#))
- Operating temperature: 0° to 70° C; 95% relative humidity, non-condensing
- UL recognized, CSA certified, and CE compliant

### A Note on Fuses

These G4 racks come equipped with a 1A fuse, which is sufficient for the Raspberry Pi, rack, and I/O modules. However, it is not sufficient if you are using USB peripherals such as USB-WiFi dongles, displays, and hard drives.

If you are using USB peripherals, you should replace the 1 A fuse in the rack with a 5 A fuse. For your convenience a compatible 5 A fuse is shipped with the OPTO-P1-40P Carrier Board.

Also be sure to see [“Power Supplies for G4” on page 47](#) and [“G4 Fuses” on page 49](#).

### Choose Your Rack

Choose a rack from the following table, and then see the referenced page in this chapter for detailed drawings and specifications. The link on the part number takes you to the product on our website.

Model	Number of Channels	Input Modules	Output Modules	AC	DC	Built-in Fuse Tester	Field Connector	Control Connector	Special Features	See
<a href="#">G4PB8H</a>	8	●	●	●	●	●	screw-type barrier strip	50-pin header connector	Works with Opto 22 PBSA/B/C power supply. Power indicator light.	<a href="#">page 7</a>
<a href="#">G4PB16H</a>	16	●	●	●	●	●	screw-type barrier strip	50-pin header connector	Works with Opto 22 PBSA/B/C power supply. Power indicator light.	<a href="#">page 8</a>

## G4PB8H Mounting Rack

### Description

The G4PB8H I/O mounting rack accommodates up to eight G4 I/O modules.

The logic supply is fused with a 1A fuse. See “A Note on Fuses” on page 6.

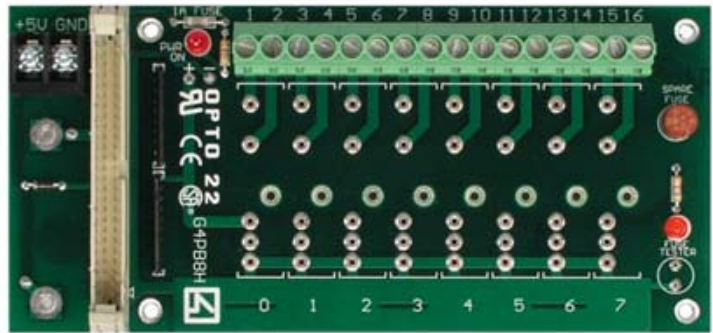

### Specifications

Operating temperature	0° to 70° C
Interface connectors	
Field:	Screw-type barrier strip accommodates up to 10 AWG wire
Control:	50-pin header connector
Power:	Two-position screw terminal or Opto 22 PBSA/B/C power supply

### Dimensions—G4PB8H

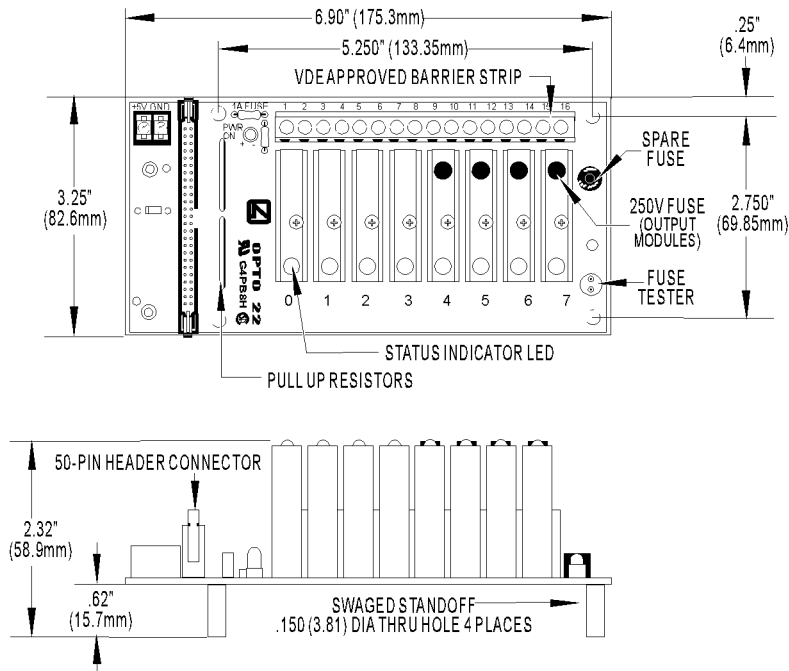

### Connections—G4PB8H

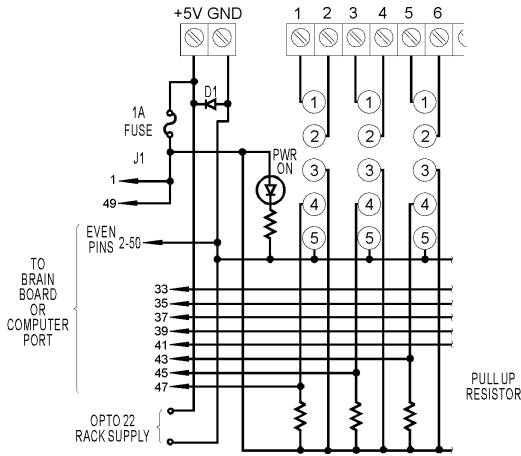

Notes:

1. Even pins on control connector are connected by etch to common.
2. +VCC and return connected to terminals marked +5V and GND.
3. At each module position on the field terminal strip, the lower number is always connected to pin 1 of the I/O module.
4. Use only 5 VDC logic modules when using the mounting rack with a Raspberry Pi.

Module Position	Control (Header Connector)	Field (Terminal Strip)
0	47	1 and 2
1	45	3 and 4
2	43	5 and 6
3	41	7 and 8
4	39	9 and 10
5	37	11 and 12
6	35	13 and 14
7	33	15 and 16

## G4PB16H Mounting Rack

### Description

The G4PB16H I/O mounting rack accommodates up to 16 G4 I/O modules. The logic supply is fused with a 1A fuse. See “A Note on Fuses” on page 6.

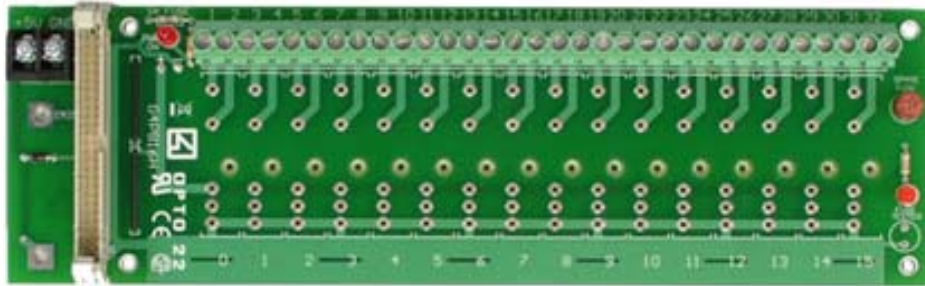

### Specifications

Operating temperature	0° to 70° C
Interface connectors	
Field:	Screw-type barrier strip accommodates up to 10 AWG wire
Control:	50-pin header connector
Power:	Two-position screw terminal for Opto 22 PBSA/B/C power supply

### Dimensions—G4PB16H

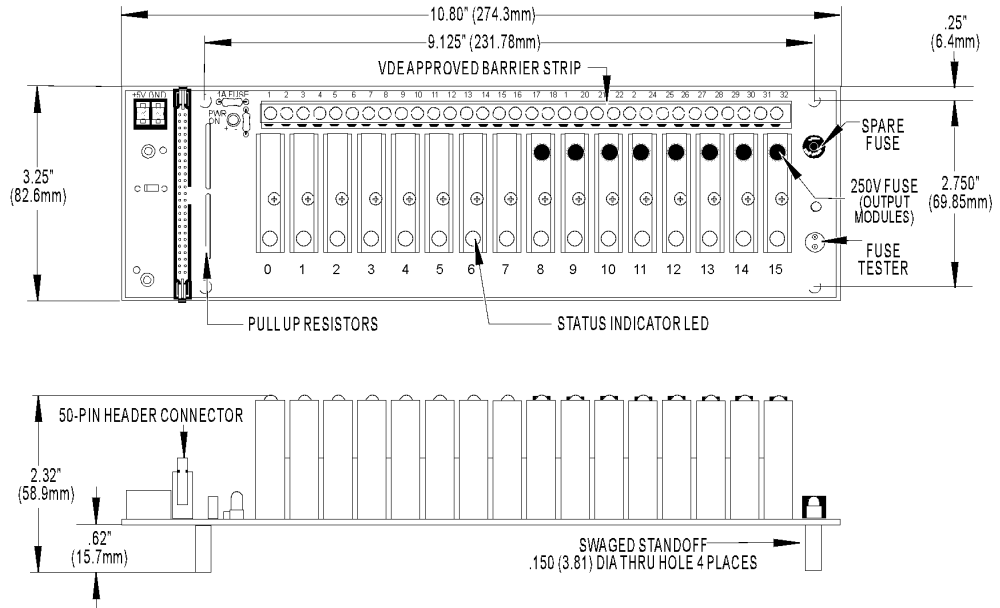

### Connections—G4PB16H

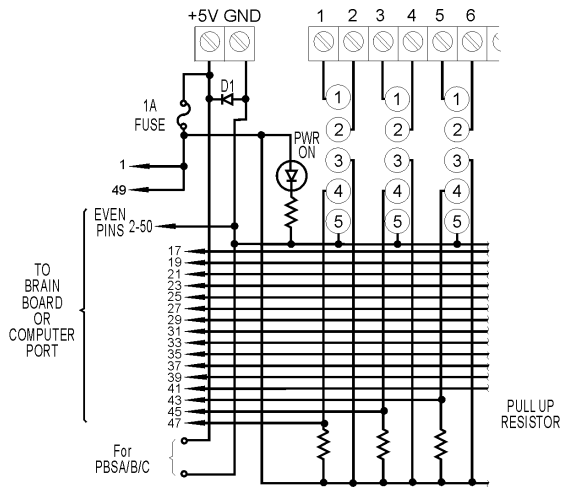

Notes:

1. Even pins on control connector are connected by etch to common.
2. +VCC and return connected to terminals marked +5V and GND.
3. At each module position on the field terminal strip, the lower number is always connected to pin 1 of the I/O module.
4. Use only 5 VDC logic modules when using the mounting rack with a Raspberry Pi.

Module Position	Control (Header Connector)	Field (Terminal Strip)
0	47	1 and 2
1	45	3 and 4
2	43	5 and 6
3	41	7 and 8
4	39	9 and 10
5	37	11 and 12
6	35	13 and 14
7	33	15 and 16
8	31	17 and 18
9	29	19 and 20
10	27	21 and 22
11	25	23 and 24
12	23	25 and 26
13	21	27 and 28
14	19	29 and 30
15	17	31 and 32

## Choose your G4 I/O Modules

Once you have your rack, you're ready to choose input and output modules.

- *Input* modules monitor things; they bring status information into your Raspberry Pi.
- *Output* modules control things; based on logic in your Pi, they turn things on or off.

### Features

The following features apply to all G4 I/O modules:

- Maximum flexibility with one point per module
- UL recognized, CSA certified, and CE compliant
- Passed NEMA Showering Arc Test (ICS 2-230)
- Meet IEEE Surge Withstand Specification (IEEE-472)
- Operating temperature: - 30° to 70° C.

### Choose Your Module

Choose a module from the following table, then see the referenced page for detailed drawings and specifications. The link on the module part number takes you to the product on our website.

Input	Output	AC	DC	Field Voltage	Special Features	Module	See
●		● <sup>1</sup>	●	10–32 VDC 12–32 VAC		G4IDC5	<a href="#">page 11</a>
●			●	2.5–28 VDC	Low-voltage input	G4IDC5D	<a href="#">page 11</a>
●		● <sup>1</sup>	●	35–60 VDC/AC		G4IDC5G	<a href="#">page 11</a>
●		● <sup>1</sup>	●	10–32 VDC 12–32 VAC	Manual/auto switch	G4IDC5MA	<a href="#">page 11</a>
●		●	● <sup>2</sup>	90–140 VAC/DC		G4IAC5	<a href="#">page 14</a>
●		●	● <sup>2</sup>	180–280 VAC/DC		G4IAC5A	<a href="#">page 14</a>
●		●	●	90–140 VAC/DC	Low input resistance	G4IAC5L	<a href="#">page 14</a>
●		●	● <sup>2</sup>	90–140 VAC/DC	manual/auto switch	G4IAC5MA	<a href="#">page 14</a>
●		●	●	NA	Simulates input	G4SWIN	<a href="#">page 16</a>
	●		●	5–60 VDC		G4ODC5	<a href="#">page 17</a>
	●		●	5–200 VDC		G4ODC5A	<a href="#">page 17</a>
	●		●	5–60 VDC	Manual/auto switch	G4ODC5MA	<a href="#">page 17</a>
	●	●		120 VAC		G4OAC5	<a href="#">page 19</a>
	●	●		120/240 VAC		G4OAC5A	<a href="#">page 19</a>

<sup>1</sup> These DC input modules work with either DC or AC field voltages.

<sup>2</sup> These AC input modules work with either AC or DC field voltages.

Input	Output	AC	DC	Field Voltage	Special Features	Module	See
	●	●		120/240 VAC	Normally closed	G4OAC5A5	page 19
	●	●		120 VAC	Manual/auto switch	G4OAC5MA	page 19
	●	●		120/240 VAC	Manual/auto switch	G4OAC5AMA	page 19
	●	●	●	NA	Simulates output	G4SWOUT	page 21

<sup>1</sup> These DC input modules work with either DC or AC field voltages.

<sup>2</sup> These AC input modules work with either AC or DC field voltages.

## G4 Digital DC Input Modules



### Description

Opto 22's G4 DC input modules are used to detect on/off DC voltage levels. Typical applications for DC input modules include sensing the presence or absence of voltage with devices such as proximity switches, limit switches, selector switches, push buttons, photoelectric switches, and TTL-compatible devices.

All modules include a built-in LED status indicator.

All DC input modules except the G4IDC5K and the G4IDC5D are designed with filtering on the input and a hysteresis amplifier, providing high noise rejection and transient-free, "clean" switching.

Special features:

- The low-cost G4IDC5D is used for data acquisition.
- The G4IDC5MA features a manual-on/manual-off/automatic switch, ideal for diagnostic testing of control applications.

### Specifications—DC Input Modules

	Units	G4IDC5	G4IDC5D	G4IDC5G
Input voltage range	VDC VAC	10–32 12–32	2.5–28 —	35–60 35–60
Key feature		—	High speed	—
Input current at maximum line	mA	25	30	6
Isolation, input-to-output (transient):				
1 ms	V	4000	4000	4000
1 minute	V	1500	1500	1500
Turn-on time	ms	5	1	10
Turn-off time	ms	5	1.5	10
Input allowed for off-state	mA, V	1, 3	0.2, 1	0.7, 7
Nominal output supply voltage	VDC	5	5	5
Output supply voltage range	VDC	4.5–6	4.5–6	4.5–6

	Units	G4IDC5	G4IDC5D	G4IDC5G
Output supply current at nominal logic voltage	mA	12	12	12
Input resistance (R1 in schematic)	ohms	1.5 K	900	10 K
Control resistance (Rc in schematic)	ohms	220	470	220
Output voltage drop	V @ 50 mA	0.4	0.4	0.4
Output current (sinking)	mA	50	50	50
Output leakage with no input	microamps @ 30 VDC	100	10	100
Transistor	V breakdown	30	30	30
Temperature:				
Operating	°C	-30 to +70	-30 to +70	-30 to +70
Storage	°C	-30 to +85	-30 to +85	-30 to +85

### Specifications—DC Input Module with manual/auto switch

	Units	G4IDC5MA
Input voltage range	VDC VAC	10–32 12–32
Key feature		Diagnostic switch
Input current at maximum line	mA	25
Isolation, input-to-output (transient):		
1 ms	V	4000
1 minute	V	1500
Turn-on time	ms	5
Turn-off time	ms	5
Input allowed for off-state	mA, V	1, 3
Nominal output supply voltage	VDC	5
Output supply voltage range	VDC	4.5–6
Output supply current at nominal logic voltage	mA	12
Input resistance (R1 in schematic)	ohms	1.5 K
Control resistance (Rc in schematic)	ohms	220
Output voltage drop	V @ 50 mA	0.4
Output current (sinking)	mA	50
Output leakage with no input	microamps @ 30 VDC	100
Transistor	V breakdown	30
Temperature:		
Operating	°C	-30 to +70
Storage	°C	-30 to +85

\* At 5Vp-p square wave input, 50% duty cycle.

\*\* Not for use with Opto 22 brains.

### Dimensions—DC Input Modules

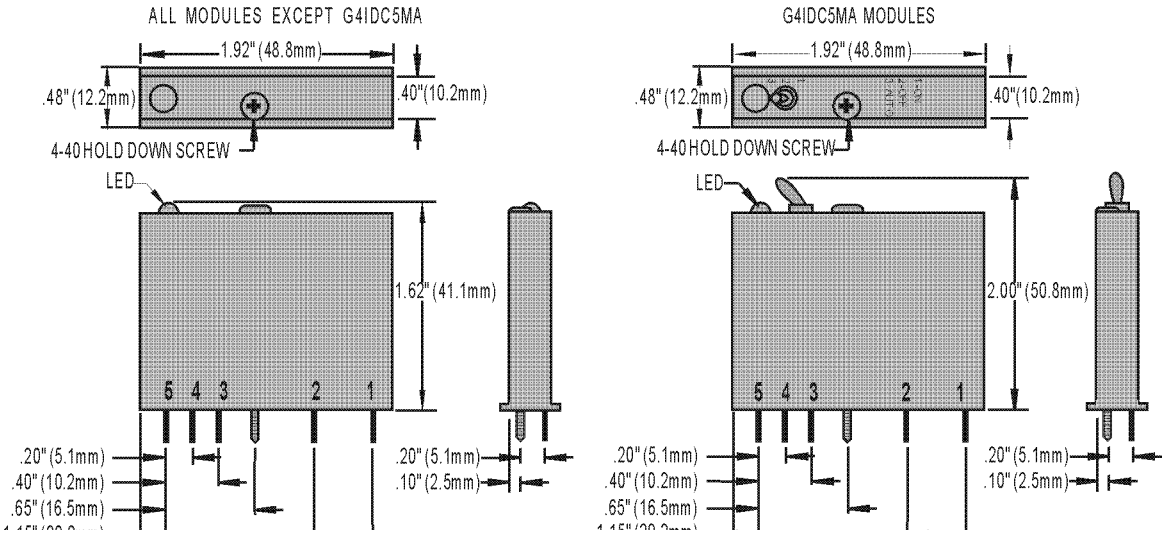

### Schematics—DC Input Modules

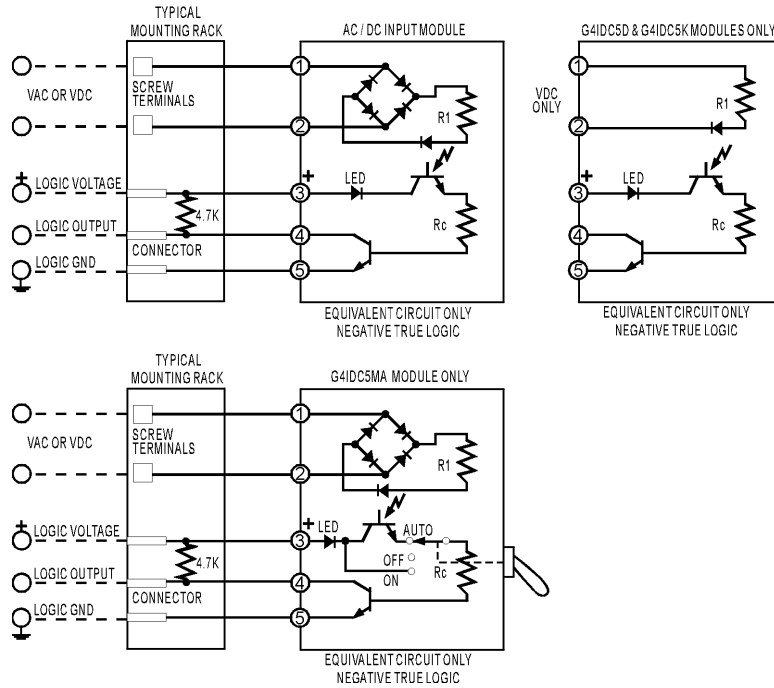

To wire sensors to G4 inputs, see “G4 I/O Field Wiring” on page 22.

## G4 Digital AC Input Modules



### Description

Opto 22's G4 AC input modules are used to detect on/off AC voltage levels. Typical applications for AC input modules include sensing the presence or absence of voltage with devices such as proximity switches, limit switches, float switches, selector switches, push buttons, toggle switches, and thermostats.

All modules include a built-in LED status indicator.

All AC input modules are designed with filtering on the input and a hysteresis amplifier, providing high noise rejection and transient-free "clean" switching.

The G4IAC5MA module features a manual-on/manual-off/automatic switch, ideal for diagnostic testing of control applications.

### Specifications—AC Input Modules

	Units	G4IAC5*	G4IAC5L*	G4IAC5A*	G4IAC5MA*
Input voltage range	VAC or VDC	90–140	90–140	180–280	90–140
Key feature	--	--	Low R in	--	Diagnostic switch
Input current at maximum line	mA	5	11	5	5
Isolation, input-to-output (transient):					
1 ms	V	4000	4000	4000	4000
1 minute	V	1500	1500	1500	1500
Turn-on time	ms	20	20	20	20
Turn-off time	ms	20	20	20	20
Input allowed for off-state	mA, V	1.4, 40	3, 45	0.7, 45	1.4, 40
Nominal output voltage supply	VDC	5	5	5	5
Output supply voltage range	VDC	4.5–6	4.5–6	4.5–6	4.5–6
Output supply current at nominal logic voltage	mA	12	12	12	12
Input resistance (R <sub>1</sub> in schematic)	ohms	28 K	14 K	70K	28 K
Control resistance (R <sub>c</sub> in schematic)	ohms	220	220	220	220
Output voltage drop	V @ 50 mA	0.4	0.4	0.4	0.4
Output current (sinking)	mA	50	50	50	50
Output leakage with no input	microamps @ 30 VDC	100	100	100	100
Transistor	V breakdown	30	30	30	30
Temperature					
Operating:	°C	-30 to +70	-30 to +70	-30 to +70	-30 to +70
Storage:	°C	-30 to +85	-30 to +85	-30 to +85	-30 to +85

\* Compatible with Raspberry Pi

### Dimensions—AC Input Modules

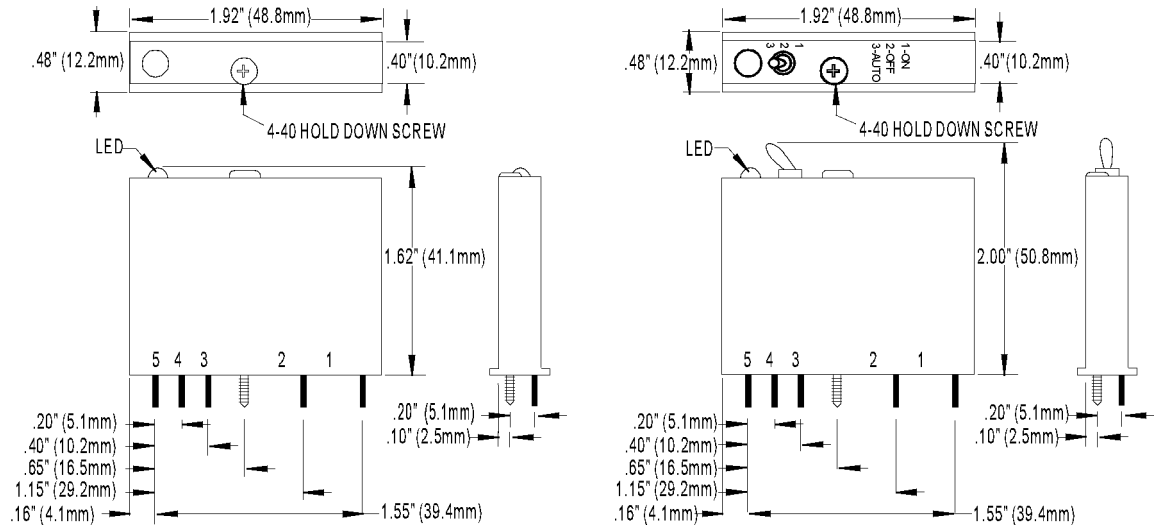

### Schematics—AC Input Modules

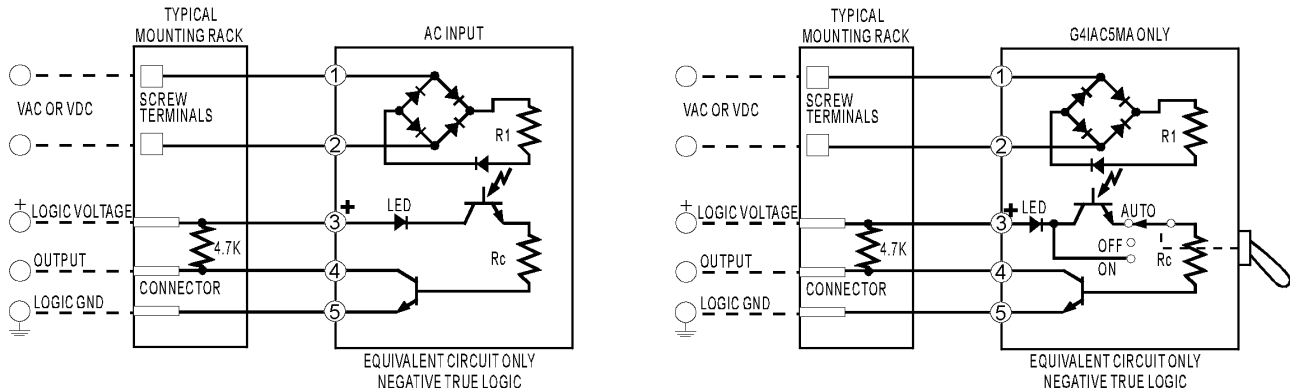

To wire sensors to G4 inputs, see [“G4 I/O Field Wiring”](#) on page 22.

## G4 Digital Input Test Module



### Description

Opto 22's G4SWIN input test module is used to simulate an input on an I/O mounting rack. This module is ideal for simulating discrete external events when testing application software.

Each module contains a toggle switch that closes a contact on the logic side. An internal resistor limits the current through the switch and provides a load similar to that of an actual input module. An internal debounce circuit allows rapid switch closures without false counts.

The G4SWIN has no internal connection between logic and field inputs. A built-in LED indicates the simulated on/off status.

### Specifications—Digital Input Test Module

Isolation, input-to-output (transient): 1 ms 1 minute	4000 volts 1500 volts
Temperature: Operating Storage	-30 to +70 °C -30 to +85 °C

### Dimensions and Schematics—Digital Input Test Module

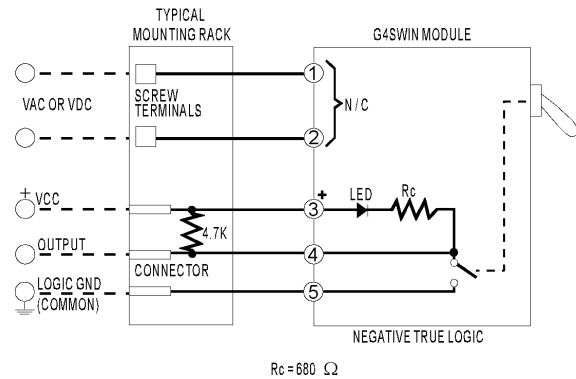
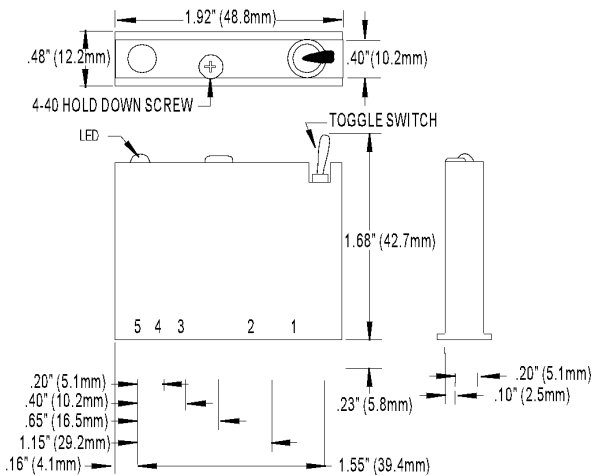

## G4 Digital DC Output Modules



### Description

Opto 22's G4 DC output modules are used to control or switch DC loads. Typical applications for DC output modules include switching loads such as DC relays, solenoids, motor starters, lamps, and indicators.

All modules include a built-in LED status indicator.

The G4ODC5MA module features a manual-on/manual-off/automatic switch, ideal for diagnostic testing of control applications.

### Specifications—DC Output Modules

	Units	G4ODC5	G4ODC5A	G4ODC5MA
Maximum line voltage	VDC	60	200	60
Output voltage range	VDC	5–60	5–200	5–60
Key feature	—	—	—	Diagnostic switch
Current rating:				
At 45 °C ambient	A	3	1	3
At 70 °C ambient	A	2	0.55	2
Isolation input-to-output (transient):				
1 ms	volts	4000	4000	4000
1 minute		1500	1500	1500
Off-state leakage at maximum voltage	mA	1	1	1
Control resistance ( $R_c$ in schematic)	W	220	220	220
One-second surge	A	5	5	5
Turn-on time	micro-seconds	100	100	100
Turn-off time	micro-seconds	750	750	750
Output voltage drop maximum peak	V	1.6	1.6	1.6
Nominal logic voltage	VDC	5	5	5
Logic voltage range	VDC	4–8	4–8	4–8
Logic pickup voltage	VDC	4	4	4
Logic dropout voltage	VDC	1	1	1
Logic input current at nominal logic voltage	mA	12	12	12
Temperature:				
Operating	°C	-30 to +70	-30 to +70	-30 to +70
Storage	°C	-30 to +85	-30 to +85	-30 to +85

### Dimensions—DC Output Modules

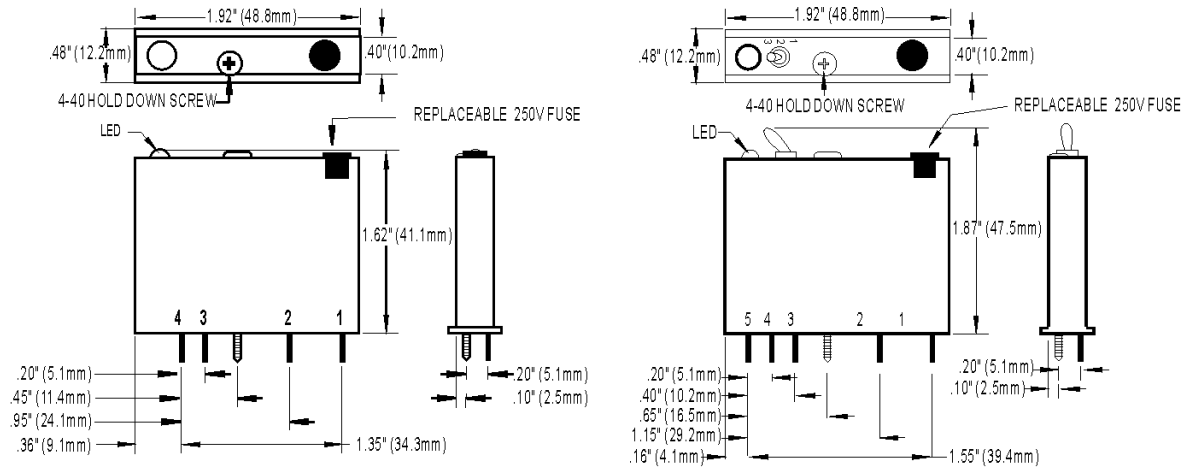

### Schematics—DC Output Modules

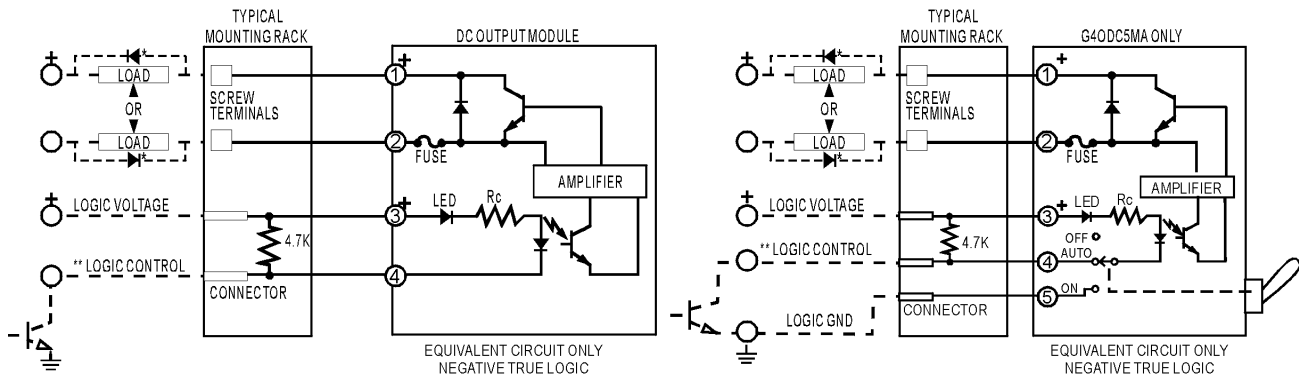

\* Commutation diode must be used on inductive loads. Typically, use diode IN4005.  
 \*\* Control line is compatible with totem pole or tri-state output device.

To wire devices to G4 outputs, see “G4 I/O Field Wiring” on page 22.

## G4 Digital AC Output Modules



### Description

Opto 22's G4 AC output modules are used to control or switch AC loads. Typical applications for AC output modules include switching loads such as AC relays, solenoids, motor starters, heaters, lamps, and indicators.

Each module features zero voltage turn-on and zero current turn-off. All AC output modules are equivalent to single-pole, single-throw, normally open contacts (Form A, SPST-NO) except the G4OAC5A5, which is equivalent to a single-pole, single-throw, normally closed contact (Form B, SPST-NC).

All digital AC output modules include a built-in LED status indicator.

The G4OAC5MA and G4OAC5AMA modules each feature a manual-on/manual-off/automatic switch, ideal for diagnostic testing of control applications.

### Specifications—AC Output Modules

	Units	G4OAC5	G4OAC5A	G4OAC5A5	G4OAC5MA	G4OAC5AMA
Nominal line voltage	VAC	120	120/240	120/240	120	120/240
Output voltage range	VAC	12–140	24–280	24–280	12–140	24–280
Key feature	—	—	—	Normally closed	Diagnostic switch	Diagnostic switch
Current rating: At 45 °C ambient At 70 °C ambient	A A	3 2	3 2	3 2	3 2	3 2
UL Motor Load Rating	A	1.5	1.5	1.5	1.5	1.5
Isolation input-to-output (transient): 1 ms 1 minute	volts	4000 1500	4000 1500	4000 1500	4000 1500	4000 1500
Off-state leakage at nominal voltage (60 Hz)	mA <sub>RMS</sub>	5	1.25/2.5	1.25/2.5	5	1.25/2.5
Nominal logic voltage	VDC	5	5	5	5	5
Logic voltage range	VDC	4–8	4–8	4–8	4–8	4–8
Logic pickup voltage	VDC	4	4	4	4	4
Logic dropout voltage	VDC	1	1	1	1	1
Logic input current at nominal logic voltage	mA	12	12	12	12	12
Control resistance (Rc in schematic)	ohms	220	220	220	220	220
One-cycle surge	A peak	80	80	80	80	80
Turn-on time @ 60 Hz	milliseconds	≤8.3**	≤8.3**	≤8.3**	≤8.3**	≤8.3**
Turn-off time @ 60 Hz	milliseconds	≤8.3***	≤8.3***	≤8.3***	≤8.3***	≤8.3***
Peak repetitive voltage	VAC	500	500	500	500	500
Minimum load current	mA	20	20	20	20	20

	Units	G4OAC5	G4OAC5A	G4OAC5A5	G4OAC5MA	G4OAC5AMA
Output voltage drop maximum peak	V	1.6	1.6	1.6	1.6	1.6
Operating frequency	Hz	25–65	25–65	25–65	25–65	25–65
dV/dT-off-state	V/micro-seconds	200	200	200	200	200
dV/dT-commutating	--	snubbed for 0.5 power factor load	snubbed for 0.5 power factor load	snubbed for 0.5 power factor load	snubbed for 0.5 power factor load	snubbed for 0.5 power factor load
Temperature Operating:	°C	-30 to +70	-30 to +70	-30 to +70	-30 to +70	-30 to +70
Storage:	°C	-30 to +85	-30 to +85	-30 to +85	-30 to +85	-30 to +85

\*\* One-half cycle maximum. Module turns on at the zero volt crossing of the AC sine wave.

\*\*\* One-half cycle maximum. Module turns off at the zero current crossing of the AC sine wave.

### Dimensions—AC Output Modules

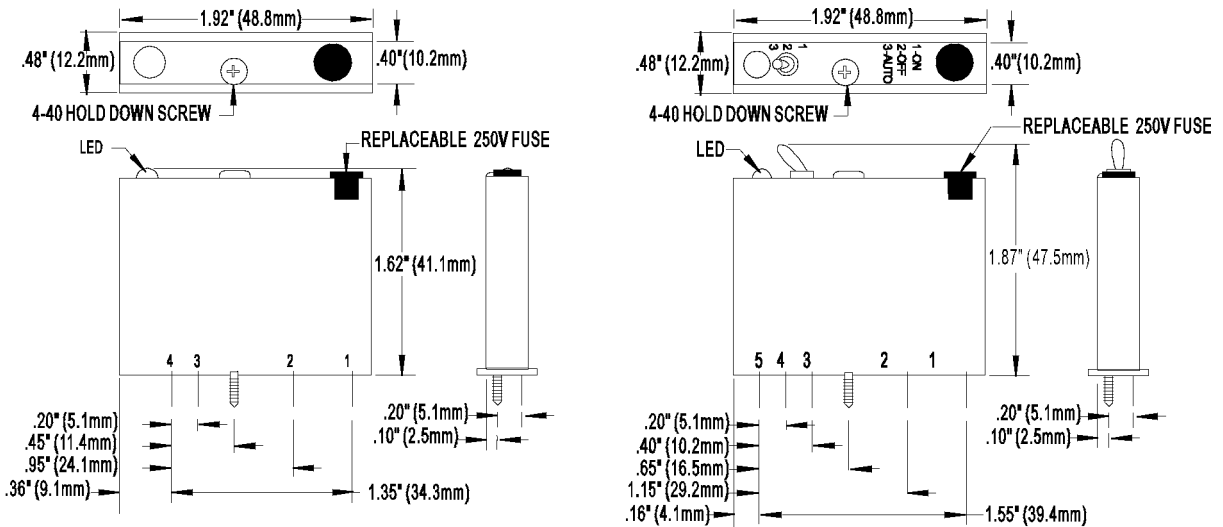

### Schematics—AC Output Modules

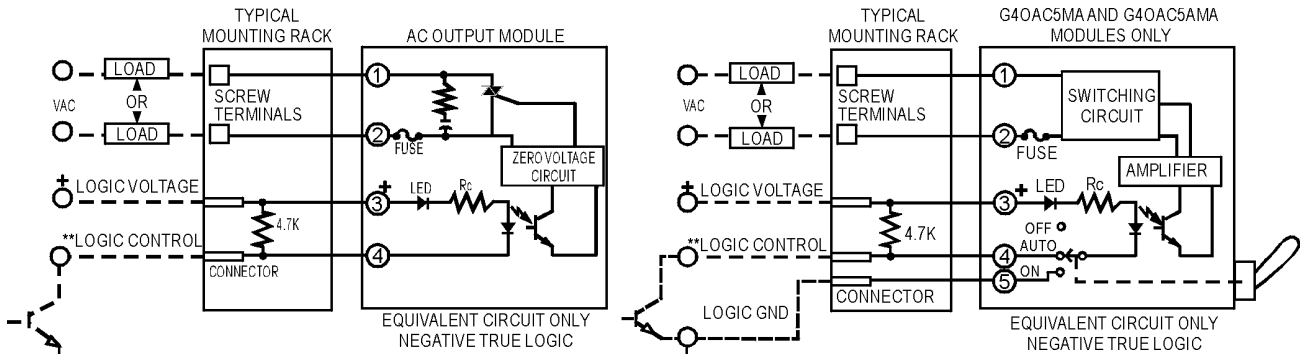

\*\*Control line is compatible with totem pole or tri-state output device.

\*\* Control line is compatible with totem pole or tri-state output device.

To wire devices to G4 outputs, see “G4 I/O Field Wiring” on page 22.

## G4 Digital Output Test Module



### Description

Opto 22's G4SWOUT output test module is used to simulate a G4 output on an I/O mounting rack. It is ideal for testing field wiring and devices by simulating an output from the computer.

Each module contains a manual toggle switch on the field side. The switch closes a contact that shorts the field terminals to turn on a field output.

The switch handles 3 amps at 250 VAC/VDC. Internally, there is no connection between the field and logic sides of the module.

### Specifications—Output Test Module

Output voltage range	250 VAC/VDC
Isolation, input-to-output (transient)	4000 volts
Temperature: Operating Storage	-30 to +70 °C -30 to +85 °C

### Dimensions and Schematics—Output Test Module

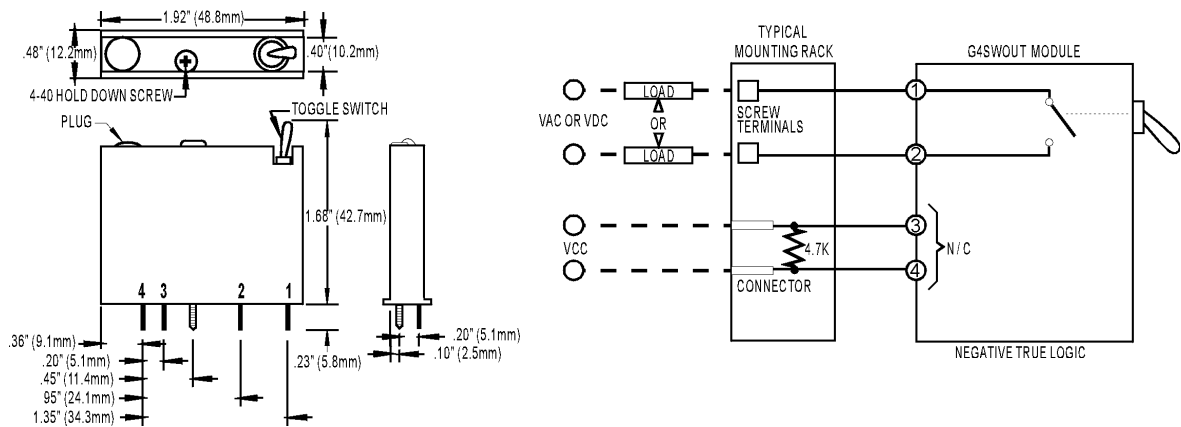

## G4 I/O Field Wiring

The diagrams in this chapter show you how to wire G4 I/O modules to your sensors and actuators.

### Input Modules Using DC Field Voltages

Use this diagram for the following modules:

G4IDC5	G4IDC5G	G4IAC5
G4IDC5B	G4IDC5K	G4IAC5A
G4IDC5D	G4IDC5MA	G4IC5MA

*NOTE: The AC input modules listed above will work with either AC or DC field voltages. If you are using them with AC voltages, see "Input Modules Using AC Field Voltages," below. If you are using them with DC field voltages, follow this diagram:*

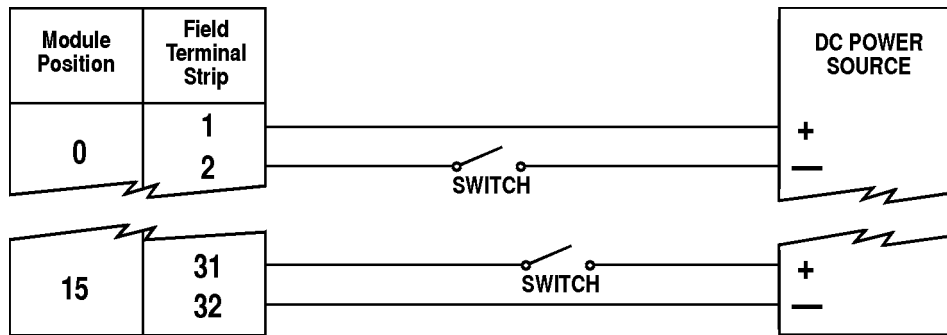

### Input Modules Using AC Field Voltages

Use this diagram for the following modules:

G4IAC5	G4IDC5
G4IAC5A	G4IDC5G
G4IAC5MA	G4ID5MA

*NOTE: The DC input modules listed at left will work with either DC or AC field voltages. For DC voltages, see "Input Modules Using DC Field Voltages," above. For AC voltages, use this diagram:*

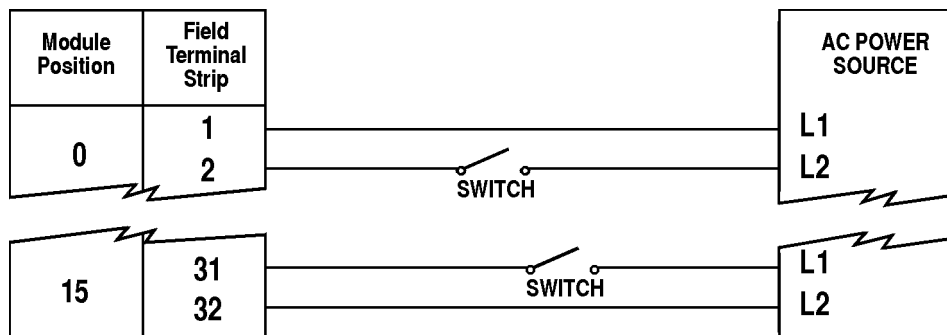

## Output Modules Using DC Field Voltages

Use this diagram for G4IAC5 modules you are using with DC voltages, and for the following modules:

- G4ODC5
- G4ODC5A
- G4ODC5MA

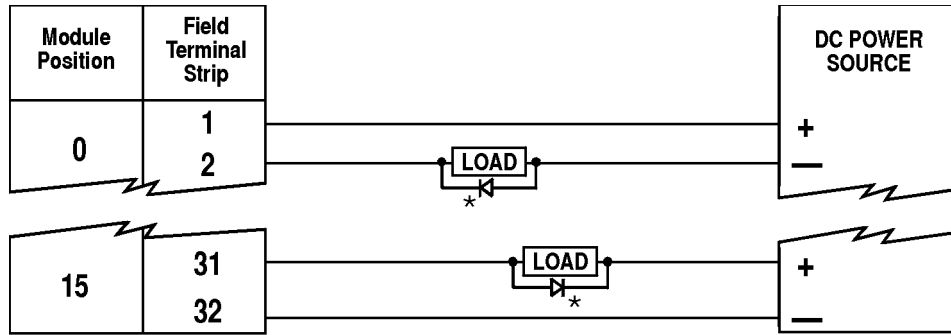

\*Note: Commutation diode must be used on inductive loads. Typically, use diode 1N4005

## Output Modules Using AC Field Voltages

Use the diagram on this page for the following modules:

- G4OAC5
- G4OAC5A
- G4OAC5A5
- G4OAC5MA
- G4OAC5AMA

*NOTE: The load can go on either terminal because AC modules are non-polar.*

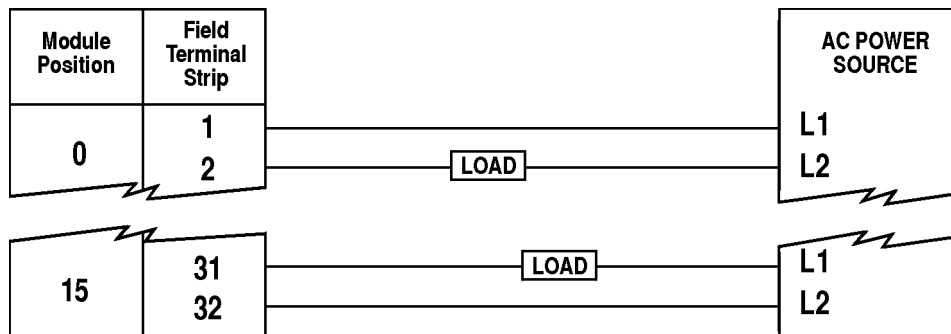



# 3: SNAP Digital I/O

## SNAP with the Raspberry Pi and Digital I/O Carrier Board

Your SNAP system—complete with the Pi, Carrier Board, SNAP mounting rack and 4 G4 I/O modules (a total of 16 I/O points)—looks something like this:

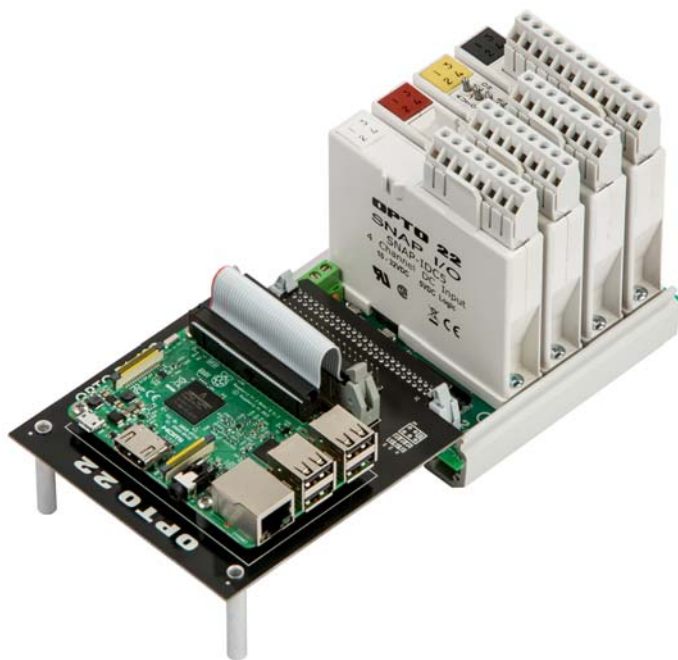

See the following pages for details on parts of the SNAP system:

- [SNAP Mounting Rack](#) page 26
- [Choose your SNAP I/O modules](#) page 27
- [Power supplies and other accessories](#) page 47

# SNAP Mounting Rack



You use the [SNAP-D4M](#) rack with the Digital I/O Carrier Board. This rack holds 4 SNAP I/O modules, each containing 4 points, for a total of 16 points on the rack.

Field devices are wired directly to the top-mounted removable connectors on the SNAP I/O modules. .

Use the two 4-40 by 1/2-inch standard machine screws provided with each module to secure the module in position.

The SNAP rack can be panel mounted or DIN-rail mounted (with optional DIN rail clips). The rack uses a single 5 VDC power source.

The rack ships with a 1 A fuse. If you are using USB peripherals, replace it with a 4 A fuse. One is included with the OPTO-P1-40P Carrier Board for convenience.

## Specifications

Length	4.19 in. (106.43 mm)
Center to center length	1.98 in. (50.29 mm)
Number of center positions	2
Power Requirements	5 VDC ± 0.25 VDC @ 200 mA max.
Operating Temperature Range	0° to 70°C
Relative Humidity	95%, non-condensing
Warranty	30 months from date of manufacture

## Power Schematic

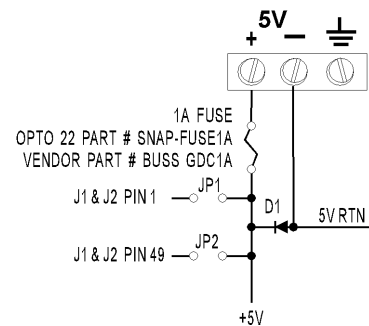

## Dimensional Drawing

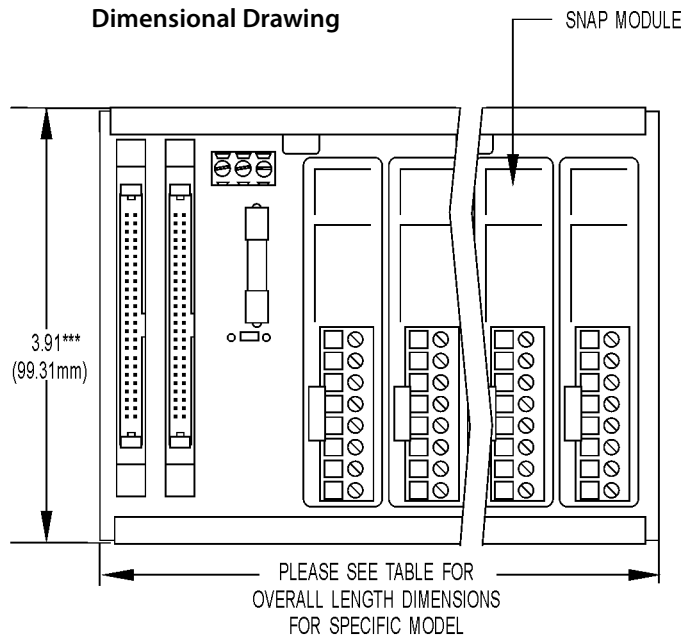

TOLERANCE LEGEND  
 \* +/- .010"  
 \*\* +/- .020"  
 \*\*\* +/- .030"  
 \*\*\*\* +/- .060"  
 NO \* REFERENCE ONLY

## Choose your SNAP I/O modules

Next, choose the input and output modules you need.

- *Input* modules monitor things; they bring status information into your Raspberry Pi.
- *Output* modules control things; based on logic in your Pi, they turn things on or off.

### Features

The following features apply to all SNAP digital I/O modules:

- Four channels per module
- Convenient pluggable wiring terminals
- Channel-specific LEDs
- UL and CE approved (some modules carry additional approvals)
- Accept 22 to 14 AWG wire

### Choose Your Module

Choose a module from the following table, then see the referenced page for detailed drawings and specifications. The link on the module part number takes you to the product on our website.

Input	Output	AC	DC	Field Voltage	Special Features	Module	See
●		●	●	90-140 VAC/VDC		<a href="#">SNAP-IAC5</a>	<a href="#">page 29</a>
●		●	●	180-280 VAC/VDC		<a href="#">SNAP-IAC5A</a>	<a href="#">page 29</a>
●		●	●	90-140 VAC/VDC	Isolated channels, manual/auto switches	<a href="#">SNAP-IAC5MA</a>	<a href="#">page 29</a>
●		●	●	10-32 VAC/VDC		<a href="#">SNAP-IDC5</a>	<a href="#">page 30</a>
●			●	2.5-28 VDC		<a href="#">SNAP-IDC5D</a>	<a href="#">page 30</a>
●		●	●	35-75 VAC/VDC		<a href="#">SNAP-IDC5G</a>	<a href="#">page 30</a>
●			●	15-32 VDC	Leakage-tolerant	<a href="#">SNAP-IDC5-HT</a>	<a href="#">page 30</a>
●		●	●	10-32 VDC/VAC	Isolated channels, manual/auto switches	<a href="#">SNAP-IDC5MA</a>	<a href="#">page 29</a>
●		●	●	NA	Contact status, normally open	<a href="#">SNAP-IDC5-SW</a>	<a href="#">page 31</a>
●			●	NA	Contact status, normally closed	<a href="#">SNAP-IDC5-SW-NC</a>	<a href="#">page 31</a>
	●	●		12-250 VAC		<a href="#">SNAP-OAC5</a>	<a href="#">page 33</a>
	●	●		12-250 VAC	Isolated channels	<a href="#">SNAP-OAC5-I</a>	<a href="#">page 33</a>
	●	●		12-250 VAC	Isolated channels, manual/auto switches	<a href="#">SNAP-OAC5MA</a>	<a href="#">page 33</a>
	●		●	5-60 VDC	Load sourcing	<a href="#">SNAP-ODC5SRC</a>	<a href="#">page 34</a>
	●		●	5-60 VDC	Load sinking	<a href="#">SNAP-ODC5SNK</a>	<a href="#">page 34</a>
	●		●	5-200 VDC	Load sinking	<a href="#">SNAP-ODC5ASNK</a>	<a href="#">page 35</a>

Input	Output	AC	DC	Field Voltage	Special Features	Module	See
	●		●	5-60 VDC	Isolated channels, manual/auto switches	SNAP-ODC5MA	<a href="#">page 35</a>
	●		●	5-60 VDC	Isolated channels	SNAP-ODC5-I	<a href="#">page 35</a>
	●		●	5-200 VDC	Isolated channels	SNAP-ODC5A-I	<a href="#">page 35</a>
	●			NA	Mechanical power relay, Form C	SNAP-OMR6-C	<a href="#">page 36</a>
	●			NA	Mechanical power relay, Form C, with integrated transient suppression	SNAP-OMR6T-C	<a href="#">page 36</a>

## SNAP Digital Input Modules

Opto 22's SNAP input modules are used to sense on or off status for AC or DC voltages from such sources as proximity switches, push buttons, or auxiliary contacts.

Most SNAP digital input modules can handle either AC or DC input voltage. Check module specs below to be sure.

Special features:

- The SNAP-IDC5G is ideal for detecting 48 VDC in telecom applications.
- The SNAP-IDC5-HT is designed for sensors that have a high leakage current.
- SNAP-IAC5MA and SNAP-IDC5MA feature manual-on/manual-off/automatic switches, ideal for testing control applications. The switches override input from field devices, so you can determine whether a problem lies in the application or in the device.

For wiring diagrams, see [page 38](#). For dimensional drawings, see [page 41](#).



SNAP digital input module



Input module with manual/auto switches

## Specifications: SNAP Digital Input Modules

	SNAP-IAC5	SNAP-IAC5A	SNAP-IAC5MA	SNAP-IDC5MA
Key Feature	--	--	Diagnostic switches	Diagnostic switches
Wire size	22 to 14 AWG	22 to 14 AWG	22 to 14 AWG	22 to 14 AWG
Torque, hold-down screws	4 in-lb (0.45 N-m)	4 in-lb (0.45 N-m)	4 in-lb (0.45 N-m)	4 in-lb (0.45 N-m)
Torque, connector screws	5.26 in-lb (0.6 N-m)	5.26 in-lb (0.6 N-m)	5.26 in-lb (0.6 N-m)	5.26 in-lb (0.6 N-m)
<b>Field Side Ratings (each channel)</b>				
Nominal Input Voltage	120 VAC/VDC	240 VAC/VDC	120 VAC/VDC	24 VAC/VDC
Channel-to-channel isolation	300 VAC (1,500 V transient)	300 VAC (1,500 V transient)	300 VAC (1,500 V transient)	300 VAC (1,500 V transient)
Input Voltage Range	90–140 VAC/VDC	180–280 VAC/VDC	90–140 VAC/VDC	10–32 VAC/VDC
Turn-on Voltage	90 VAC/VDC	180 VAC/VDC	90 VAC/VDC	10 VAC/VDC
Turn-off Voltage	35 VAC/VDC	35 VAC/VDC	35 VAC/VDC	3 VAC/VDC
Input Resistance	169 K ohms (nominal)	305 K ohms (nominal)	169 K ohms (nominal)	15 K ohms (nominal)
<b>Logic Side Ratings</b>				
Logic Output Voltage	<5 V max. (on) @ 2 mA sinking 2.7 V min. (off) @ 400 mA sourcing	<5 V max. (on) @ 2 mA sinking 2.7 V min. (off) @ 400 mA sourcing	<5 V max. (on) @ 2 mA sinking 2.7 V min. (off) @ 400 mA sourcing	<0.5 V max. (on) @ 2 mA sinking 2.7 V min. (off) @ 400 mA sourcing
Logic Supply Voltage*	5 VDC ± 0.25 VDC	5 VDC ± 0.25 VDC	5 VDC ± 0.25 VDC	5 VDC ± 0.25 VDC
Logic Supply Current	50 mA maximum	50 mA maximum	50 mA maximum	50 mA maximum
Negative True Logic Output Drive	TTL 74 Series = 1 UL TTL 74LS Series = 5 UL	TTL 74 Series = 1 UL TTL 74LS Series = 5 UL	TTL 74 Series = 1 UL TTL 74LS Series = 5 UL	TTL 74 Series = 1 UL TTL 74LS Series = 5 UL
<b>Module Ratings</b>				
Number of Channels Per Module	4	4	4	4
Turn-on Time	30 msec	30 msec	30 msec	5 msec
Turn-off Time	30 msec	30 msec	30 msec	15 msec
Optical Isolation, Field to Logic	4,000 volts (transient)	4,000 volts (transient)	4,000 volts (transient)	4,000 volts (transient)
Temperature	-20 °C to 70 °C, operating -40 °C to 85 °C, storage	-20 °C to 70 °C, operating -40 °C to 85 °C, storage	-20 °C to 70 °C, operating -40 °C to 85 °C, storage	-20 °C to 70 °C, operating -40 °C to 85 °C, storage
Agency Approvals	UL, CE, CSA, RoHS, DFARS	UL, CE, CSA, RoHS, DFARS	UL, CE, RoHS, DFARS	CE, RoHS, DFARS
Warranty	Lifetime	Lifetime	30 months	30 months

\* When used with an I/O processor (brain or on-the-rack controller), the processor requires 5.0 to 5.2 VDC.

**Specifications: SNAP Digital Input Modules (continued)**

	SNAP-IDC5	SNAP-IDC5D	SNAP-IDC5G	SNAP-IDC5-HT
Key Feature	--	--	--	Leakage-tolerant
Wire size	22 to 14 AWG	22 to 14 AWG	22 to 14 AWG	22 to 14 AWG
Torque, hold-down screws	4 in-lb (0.45 N-m)	4 in-lb (0.45 N-m)	4 in-lb (0.45 N-m)	4 in-lb (0.45 N-m)
Torque, connector screws	5.26 in-lb (0.6 N-m)	5.26 in-lb (0.6 N-m)	5.26 in-lb (0.6 N-m)	5.26 in-lb (0.6 N-m)
<b>Field Side Ratings (each channel)</b>				
Nominal Input Voltage	24 VAC/VDC	5 VDC	48 VAC/VDC	24 VAC/VDC
Channel-to-channel isolation	300 VAC (1,500 V transient)	300 VAC (1,500 V transient)	300 VAC (1,500 V transient)	300 VAC (1,500 V transient)
Input Voltage Range	10–32 VAC/VDC	2.5–28 VDC	35–75 VAC/VDC	15–32 VAC/VDC
Turn-on Voltage	10 VAC/VDC	2.5 VDC	35 VAC/VDC	15 VAC/VDC
Turn-off Voltage	3 VAC/VDC	1 VDC	7 VAC/VDC	8 VAC/VDC
Input Resistance	15 K ohms (nominal)	3 K ohms (nominal)	64 K ohms (nominal)	3 K ohms (nominal)
<b>Logic Side Ratings</b>				
Logic Output Voltage	<.5 V max. (on) @ 2 mA sinking 2.7 V min. (off) @ 0.4 mA sourcing	<.5 V max. (on) @ 2 mA sinking 2.7 V min. (off) @ 0.4 mA sourcing	<.5 V max. (on) @ 2 mA sinking 2.7 V min. (off) @ 0.4 mA sourcing	<.5 V max. (on) @ 2 mA sinking 2.7 V min. (off) @ 0.4 mA sourcing
Logic Supply Voltage***	5 VDC ± 0.25 VDC	5 VDC ± 0.25 VDC	5 VDC ± 0.25 VDC	5 VDC ± 0.25 VDC
Logic Supply Current	50 mA maximum	50 mA maximum	50 mA maximum	50 mA maximum
Negative True Logic Output Drive	TTL 74 Series = 1 UL TTL 74LS Series = 5 UL	TTL 74 Series = 1 UL TTL 74LS Series = 5 UL	TTL 74 Series = 1 UL TTL 74LS Series = 5 UL	TTL 74 Series = 1 UL TTL 74LS Series = 5 UL
<b>Module Ratings</b>				
Number of Channels Per Module	4	4	4	4
Turn-on Time	5 msec	1 msec	5 msec	20 msec
Turn-off Time	15 msec	1 msec	15 msec	25 msec
Optical Isolation (Field Side to Logic Side)	4,000 volts (transient)	4,000 volts (transient)	4,000 volts (transient)	4,000 volts (transient)
Temperature	-20 to 70 °C, operating -40 to 85 °C, storage	-20 to 70 °C, operating -40 to 85 °C, storage	-20 to 70 °C, operating -40 to 85 °C, storage	-20 to 70 °C, operating -40 to 85 °C, storage
Agency Approvals	UL, CE, CSA, RoHS, DFARS	UL, CE, CSA, RoHS, DFARS	UL, CE, RoHS, DFARS	CE, RoHS, DFARS
Warranty	Lifetime	Lifetime	Lifetime	Lifetime

\* At 20kHz, 5Vp-p square wave input, 50% duty cycle.

\*\* At 20kHz, 28Vp-p square wave input, 50% duty cycle.

\*\*\* When used with an I/O processor (brain or on-the-rack controller), the processor requires 5.0 to 5.2 VDC.

## SNAP Dry Contact Modules

The SNAP-IDC5-SW and SNAP-IDC5-SW-NC modules supply power to an external dry contact switch and sense switch closure (SNAP-IDC5-SW) or opening (SNAP-IDC5-SW-NC).

For wiring diagram, see [page 39](#). For dimensional drawings, see [page 41](#).



### Specifications: SNAP Dry Contact Modules

Field Side Ratings (each channel)	
Open Circuit Voltage (Switch Open)	15 VDC typical
Short Circuit Current (Switch Closed)	7 milliamps nominal
Minimum Off Resistance	>20 K ohms
Maximum Allowable On Resistance (Wire + Contact Resistance)	500 ohms
Logic Side Ratings	
Logic Output Voltage for SNAP-IDC5-SW (normally open)	<0.5 V max. (switch closed; LED on) @ 2 mA sinking 2.7 V min. (switch open; LED off) @ 0.4 mA sourcing
Logic Output Voltage for SNAP-IDC5-SW-NC (normally closed)	<0.5 V max. (switch closed; LED off) @ 2 mA sinking 2.7 V min. (switch open; LED on) @ 0.4 mA sourcing
Maximum Operating Common Mode Voltage (Field Term to Logic Connector)	250 V
Power Requirements	5 VDC ( $\pm 0.25$ ) @ 200 mA
Module Ratings	
Number of Channels Per Module	4
Turn-on Time	5 msec
Turn-off Time	25 msec
Channel-to-channel Isolation	None
Input-to-output Isolation	1500 V AC/DC
Wire size	22 to 14 AWG
Torque, hold-down screws	4 in-lb (0.45 N-m)
Torque, connector screws	5.26 in-lb (0.6 N-m)
Temperature	-20 °C to 70 °C, operating -40 °C to 85 °C, storage
Agency Approvals	UL, CE, RoHS, DFARS FM (SNAP-IDC5SW only)
Warranty	Lifetime

## SNAP Digital Output Modules

Opto 22 SNAP digital output modules are used to switch up to four separate AC or DC loads.

Features:

- Convenient pluggable wiring terminals accept 22 to 14 AWG wire
- Channel-specific LEDs
- DC outputs available in either a source or sink configuration
- AC outputs feature zero-voltage turn on and zero-current turn off to minimize transient switching.
- Fused output modules use a standard fuse with a convenient handle for easy replacement.

Modules with special features:

- SNAP-OAC5-i, SNAP-ODC5-i, and SNAP-ODC5A-i modules provide four isolated output channels.
- SNAP-OAC5MA and SNAP-ODC5MA include manual-on/manual-off/automatic switches, ideal for diagnostic testing of control applications. The switches override output from the application, so you can quickly check field device wiring. These modules each contain four isolated channels.

For wiring diagrams, see [page 38](#). For dimensional drawings, see [page 41](#).



SNAP digital output module



Output module with manual/auto switches

## Specifications: SNAP AC Output Modules

	SNAP-OAC5	SNAP-OAC5MA	SNAP-OAC5-i
Key Feature	--	Diagnostic switches Four isolated channels	Four isolated channels
Torque, hold-down screws	4 in-lb (0.45 N-m)	4 in-lb (0.45 N-m)	4 in-lb (0.45 N-m)
Torque, connector screws	5.26 in-lb (0.6 N-m)	5.26 in-lb (0.6 N-m)	5.26 in-lb (0.6 N-m)
Field Side Ratings (each channel)			
Line Voltage - Range	12–250 VAC	12–250 VAC	12–250 VAC
Line Voltage - Nominal	120/240 VAC	120/240 VAC	120/240 VAC
Current Rating 0 °C to 70 °C Ambient	3 amps per module	3 amps per module	3 amps per module
One Cycle Surge	80 amps peak (50/60 Hz)	80 amps peak (50/60 Hz)	80 amps peak (50/60 Hz)
Minimum Load Current	20 mA	20 mA	20 mA
Output Voltage Drop	1.6 volts max.@ 0.75 amps	1.6 volts max.@ 0.75 amps	1.6 volts max.@ 0.75 amps
Off-state Leakage at Nominal Voltage - 60 Hz	2.5 mA @ 240 VAC 1.25 mA @ 120 VAC	2.5 mA @ 240 VAC 1.25 mA @ 120 VAC	2.5 mA @ 240 VAC 1.25 mA @ 120 VAC
Peak Blocking Voltage	500 V	500 V	500 V
Operating Frequency	25–65 Hz	25–65 Hz	25–65 Hz
dV/ dt - Off-state	200 volts/msec	200 volts/msec	200 volts/msec
dV/ dt - Commutating	Snubbed for rated 0.5 power factor load	Snubbed for rated 0.5 power factor load	Snubbed for rated 0.5 power factor load
Fuse (Common to all Channels)	250 VAC - 4A 5x20 mm Fast-acting Bell Fuse Part: BEL 5HF4 Opto 22 Part: SNAP-FUSE4AB	Has four isolated channels. User must provide own fusing.	Has four isolated channels. User must provide own fusing.
Channel-to-channel isolation	Not applicable	300 VAC (1500 V transient)	300 VAC (1500 V transient)
Logic Side Ratings			
Pickup Voltage	4 V @ 5.5 mA	4 V @ 5.5 mA	4 V @ 5.5 mA
Dropout Voltage	1 VDC	1 VDC	1 VDC
Control Resistance	220 ohms	220 ohms	220 ohms
Logic Supply Voltage	5 VDC ± 0.25 VDC	5 VDC ± 0.25 VDC	5 VDC ± 0.25 VDC
Logic Supply Current	50 mA maximum	50 mA maximum	50 mA maximum
Module Ratings			
Number of Channels Per Module	4	4	4
Turn-on Time	0.5 cycle maximum (zero volts crossover)	0.5 cycle maximum (zero volts crossover)	0.5 cycle maximum (zero volts crossover)
Turn-off Time	0.5 cycle maximum (zero current crossover)	0.5 cycle maximum (zero current crossover)	0.5 cycle maximum (zero current crossover)
Isolation (Field Side to Logic Side)	4,000 volts (transient)	4,000 volts (transient)	4,000 volts (transient)
Temperature	-20 ° to 70 °C, operating -40 ° to 85 °C, storage	-20 ° to 70 °C, operating -40 ° to 85 °C, storage	-20 ° to 70 °C, operating -40 ° to 85 °C, storage
Wire size range	22 to 14 AWG	22 to 14 AWG	22 to 14 AWG
Agency Approvals	UL, CE, CSA, RoHS, DFARS	UL, CE, RoHS, DFARS	UL, CE, RoHS, DFARS
Warranty	Lifetime	30 months	Lifetime

## Specifications: SNAP DC Output Modules

	SNAP-ODC5SRC	SNAP-ODC5SNK
Key Feature	Load sourcing	Load sinking
Torque, hold-down screws	4 in-lb (0.45 N-m)	4 in-lb (0.45 N-m)
Torque, connector screws	5.26 in-lb (0.6 N-m)	5.26 in-lb (0.6 N-m)
Field Side Ratings (each channel)		
Line Voltage - Range	5–60 VDC	5–60 VDC
Line Voltage - Nominal	5–48 VDC	5–48 VDC
Current Rating 0 °C to 70 °C Ambient	3 amps per module	3 amps per module
Surge Current	5 amps peak for 1 second	5 amps peak for 1 second
Minimum Load	20 mA	20 mA
Output Voltage Drop	1.6 volts max.@ 0.75 amps	1.6 volts max.@ 0.75 amps
Off-state Leakage	1 mA @ 60 VDC	1 mA @ 60 VDC
Peak Blocking Voltage	60 VDC	60 VDC
Fuse (Common to all Channels)	250 VAC - 4A 5x20 mm Fast-acting Bell Fuse Part No. BEL 5HF4 Opto 22 Part SNAP-FUSE4AB	250 VAC - 4A 5x20 mm Fast-acting Bell Fuse Part No. BEL 5HF4 Opto 22 Part SNAP-FUSE4AB
Channel-to-channel isolation	Not applicable	Not applicable
Logic Side Ratings		
Pickup Voltage	4 V @ 5.5 mA	4 V @ 5.5 mA
Dropout Voltage	1 VDC	1 VDC
Control Resistance	220 ohms	220 ohms
Logic Supply Voltage	5 VDC ± 0.25 VDC	5 VDC ± 0.25 VDC
Logic Supply Current	50 mA maximum	50 mA maximum
Module Ratings		
Number of Channels Per Module	4	4
Turn-on Time	100 usec	100 usec
Turn-off Time	750 usec	750 usec
Isolation (Field Side to Logic Side)	4,000 volts (transient)	4,000 volts (transient)
Temperature	-20 to 70 °C, operating -40 to 85 °C, storage	-20 to 70 °C, operating -40 to 85 °C, storage
Wire size range	22 to 14 AWG	22 to 14 AWG
Agency Approvals	UL, CE, CSA, RoHS, DFARS	UL, CE, CSA, RoHS, DFARS
Warranty	Lifetime	Lifetime

## Specifications: SNAP DC Output Modules (continued)

	SNAP-ODC5MA	SNAP-ODC5-i	SNAP-ODC5A-i	SNAP-ODC5ASNK
Key Feature	Diagnostic switches Four isolated channels	Four isolated channels	Four isolated channels	Load sinking
Torque, hold-down screws	4 in-lb (0.45 N-m)	4 in-lb (0.45 N-m)	4 in-lb (0.45 N-m)	4 in-lb (0.45 N-m)
Torque, connector screws	5.26 in-lb (0.6 N-m)	5.26 in-lb (0.6 N-m)	5.26 in-lb (0.6 N-m)	5.26 in-lb (0.6 N-m)
Field Side Ratings (each channel)				
Line Voltage - Range	5–60 VDC	5–60 VDC	5–200 VDC	5–200 VDC
Line Voltage - Nominal	5–48 VDC	5–48 VDC	5–200 VDC	5–200 VDC
Current Rating 0 °C to 70 °C Ambient	2 amps per module 0.5 amps per channel	3 amps per module	3 amps per module	3 amps per module
Surge Current	1.5 amps peak for 1 second	5 amps peak for 1 second	5 amps peak for 1 second	5 amps peak for 1 second
Minimum Load	20 mA	20 mA	20 mA	20 mA
Output Voltage Drop	1.6 volts max. @ 0.75 amps	1.6 volts max. @ 0.75 amps	1.6 volts max. @ 0.75 amps	1.6 volts max. @ 0.75 amps
Off-state Leakage	1 mA @ 60 VDC	1 mA @ 60 VDC	1 mA @ 200 VDC	1 mA @ 200 VDC
Peak Blocking Voltage	60 VDC	60 VDC	200 VDC	200 VDC
Fuse (Common to all Channels)	Has four isolated channels. User must provide own fusing.	Has four isolated channels. User must provide own fusing.	Has four isolated channels. User must provide own fusing.	250 VAC - 4A 5x20 mm Fast-acting Bell Fuse Part: BEL 5HF4 Opto 22 Part: SNAP-FUSE4AB
Channel-to-channel isolation	300 VAC (1500 V transient)	300 VAC (1500 V transient)	300 VAC (1500 V transient)	Not applicable
Logic Side Ratings				
Pickup Voltage	4 V @ 5.5 mA	4 V @ 5.5 mA	4 V @ 5.5 mA	4 V @ 5.5 mA
Dropout Voltage	1 VDC	1 VDC	1 VDC	1 VDC
Control Resistance	220 ohms	220 ohms	220 ohms	220 ohms
Logic Supply Voltage	5 VDC ± 0.25 VDC	5 VDC ± 0.25 VDC	5 VDC ± 0.25 VDC	5 VDC ± 0.25 VDC
Logic Supply Current	50 mA maximum	50 mA maximum	50 mA maximum	50 mA maximum
Module Ratings				
Number of Channels Per Module	4	4	4	4
Turn-on Time	100 usec	100 usec	100 usec	100 usec
Turn-off Time	750 usec	750 usec	750 usec	750 usec
Isolation (Field Side to Logic Side)	4,000 volts (transient)	4,000 volts (transient)	4,000 volts (transient)	4,000 volts (transient)
Temperature	-20 to 70 °C, operating -40 to 85 °C, storage	-20 to 70 °C, operating -40 to 85 °C, storage	-20 to 70 °C, operating -40 to 85 °C, storage	-20 to 70 °C, operating -40 to 85 °C, storage
Wire size range	22 to 14 AWG	22 to 14 AWG	22 to 14 AWG	22 to 14 AWG
Agency Approvals	UL, CE, RoHS, DFARS	UL, CE, RoHS, DFARS	UL, CE, RoHS, DFARS	UL, CE, RoHS, DFARS
Warranty	30 months	Lifetime	Lifetime	Lifetime

## SNAP Mechanical Power Relay Output Modules



SNAP mechanical power relay output modules offer four isolated channels for switching loads of up to 6 amps at 250 VAC or 30 VDC.

Each contact can carry 6 amps, and having more than one channel on at the same time does not reduce the amount of power each channel can carry.

Because these are form C modules, each of the four mechanical contacts can be wired as normally open or normally closed. Fusing is not provided; you must provide fusing when wiring the module.

See wiring diagrams on [page 40](#) and dimensional drawings on [page 44](#).

## Specifications: SNAP Mechanical Power Relay Output Modules

	SNAP-OMR6-C	SNAP-OMR6T-C
Field Side Ratings (each channel)		
Contact Configuration	Form C (SPDT, normally open or closed)	Form C (SPDT, normally open or closed)
Line Voltage - Range	0–250 VAC or 5–30 VDC	0–250 VAC or 5–30 VDC
Current Rating	6 amps switching @ 250 VAC / 30 VDC	6 amps switching @ 250 VAC / 30 VDC
Surge Current	6 amps	6 amps
Minimum Load	5 VDC, 10 mA	5 VDC, 10 mA
Contact Resistance	≤ 100 milliohms	≤ 100 milliohms
Leakage Current	none	< 1 microamp @ 250 VAC
Clamping Voltage (for transient suppression)	External transient suppression required	440 V nominal
Duty Cycle	-- Not applicable --	1 Hz
Switching Power	1500 VA / 144 W (DC)	1500 VA / 144 W (DC)
Peak Blocking Voltage	250 VAC @ 360 V <sub>pk</sub>	250 VAC @ 360 V <sub>pk</sub>
Channel-to-channel isolation	300 VAC (1500 Vtransient)	300 VAC (1500 Vtransient)
Logic Side Ratings		
Pickup Voltage	1 V @ 2 mA	1 V @ 2 mA
Dropout Voltage	4 VDC	4 VDC
Control Resistance	220 ohms	220 ohms
Logic Supply Voltage	5 VDC ± 0.25 VDC	5 VDC ± 0.25 VDC
Logic Supply Current	160 mA maximum	160 mA maximum
Module Ratings		
Number of Channels Per Module	4	4
Turn-on Time	8 milliseconds	8 milliseconds
Turn-off Time	8 milliseconds	8 milliseconds
Torque, hold-down screws	4 in-lb (0.45 N-m)	4 in-lb (0.45 N-m)
Torque, connector screws	Single gray connector: 5.26 in-lb (0.6 N-m) Black connectors: 1.7 in-lb (0.2 N-m)	5.26 in-lb (0.6 N-m)
Temperature	-20 to 70 °C, operating -30 to 85 °C, storage	-20 to 70 °C, operating -30 to 85 °C, storage
Agency Approvals	UL, CE, RoHS, DFARS	UL, CE RoHS, DFARS
Mechanical Life	10 x 10 <sup>6</sup> operations	10 x 10 <sup>6</sup> operations
Operational Life	30 x 10 <sup>3</sup> operations	30 x 10 <sup>3</sup> operations
Warranty	30 months	30 months

# Wiring Diagrams

## Wiring: Most SNAP Digital Input and Output Modules (except Dry Contact and Mechanical Power Relay Modules)

For dry contact modules, see [page 39](#). For mechanical power relay modules, see [page 40](#).

MA Modules with Manual/Auto Switches (Top View)

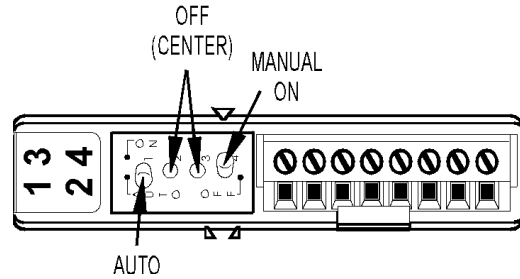

MUST OBSERVE POLARITY  
For SNAP-IDC5-FAST, SNAP-IDC5-FAST-A,  
SNAP-IDC5GF, SNAP-IDC5AF

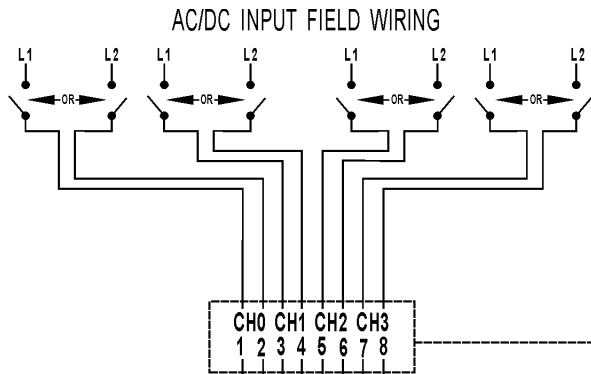
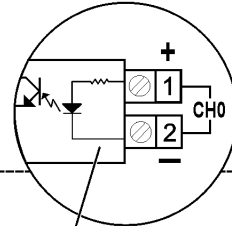

SNAP MODULE FIELD CONNECTOR  
OPTO 22 PART # SNAP-FIELDCON

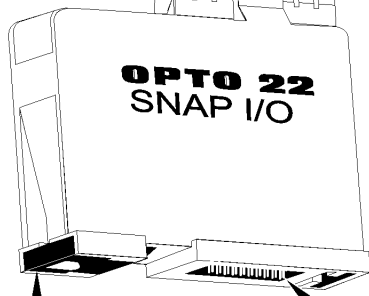

SNAP MODULE RELEASE LATCH  
OPTO 22 PART # SNAP-MODLATCH

PIN 1 (FIRST FORWARD PIN)

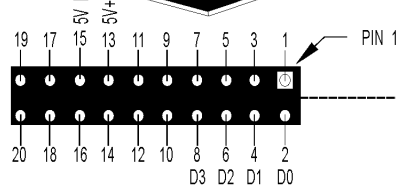

SNAP DIGITAL MODULE BASE CONTROL CONNECTOR (BOTTOM VIEW)

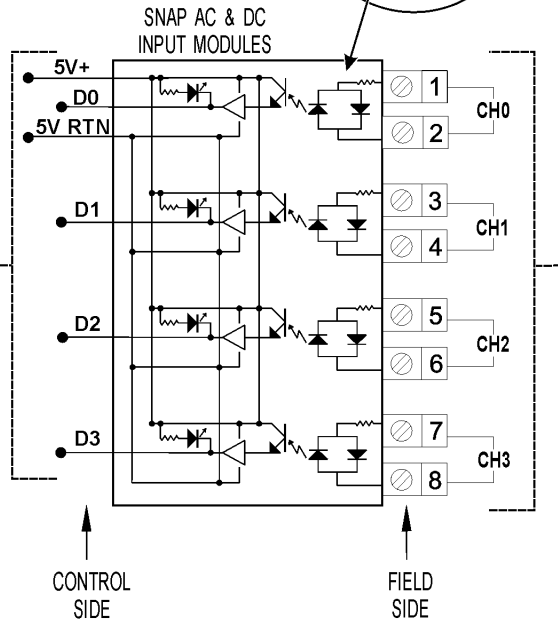

## Wiring: Dry Contact Modules

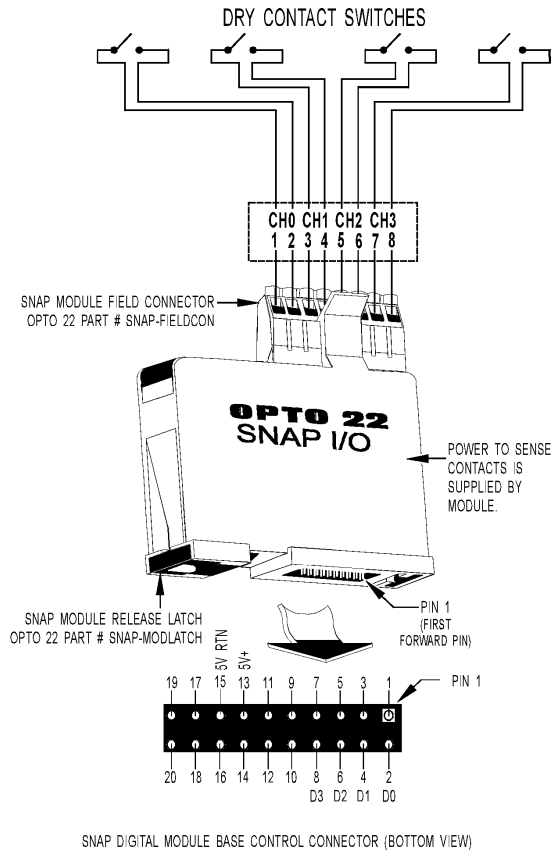

## Wiring: Mechanical Power Relay Modules

*NOTE: On all SNAP mechanical power relay modules, external transient protection is recommended for highly inductive loads.*

### SNAP-OMR6T-C Field Connections

Note: User must provide own fusing.

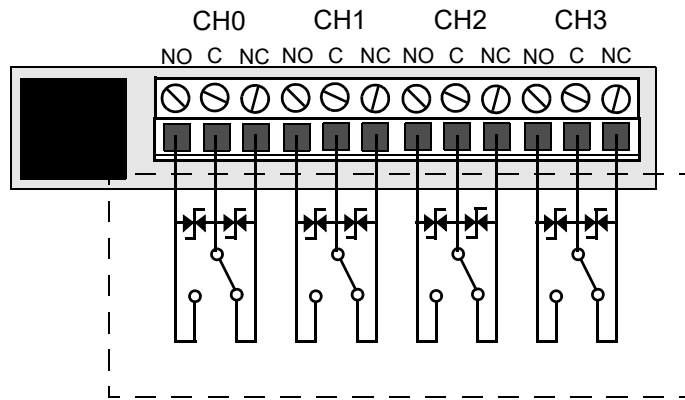

### SNAP-OMR6-C Field Connections - Gray Terminal

Note: User must provide own fusing.

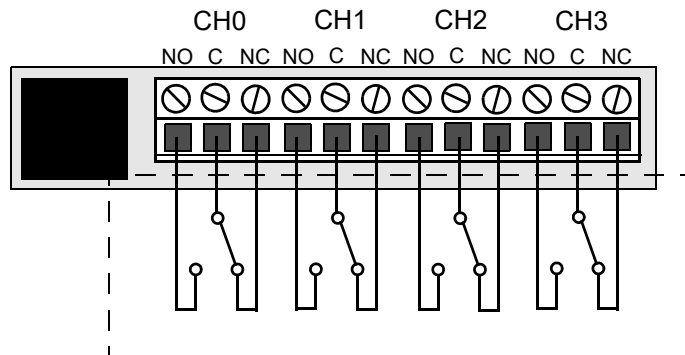

*NOTE: For DC loads, install a reverse-biased diode, such as an 1N4005 (or equivalent) at the load.*

# Dimensional Drawings

## All SNAP Input Models Except MA

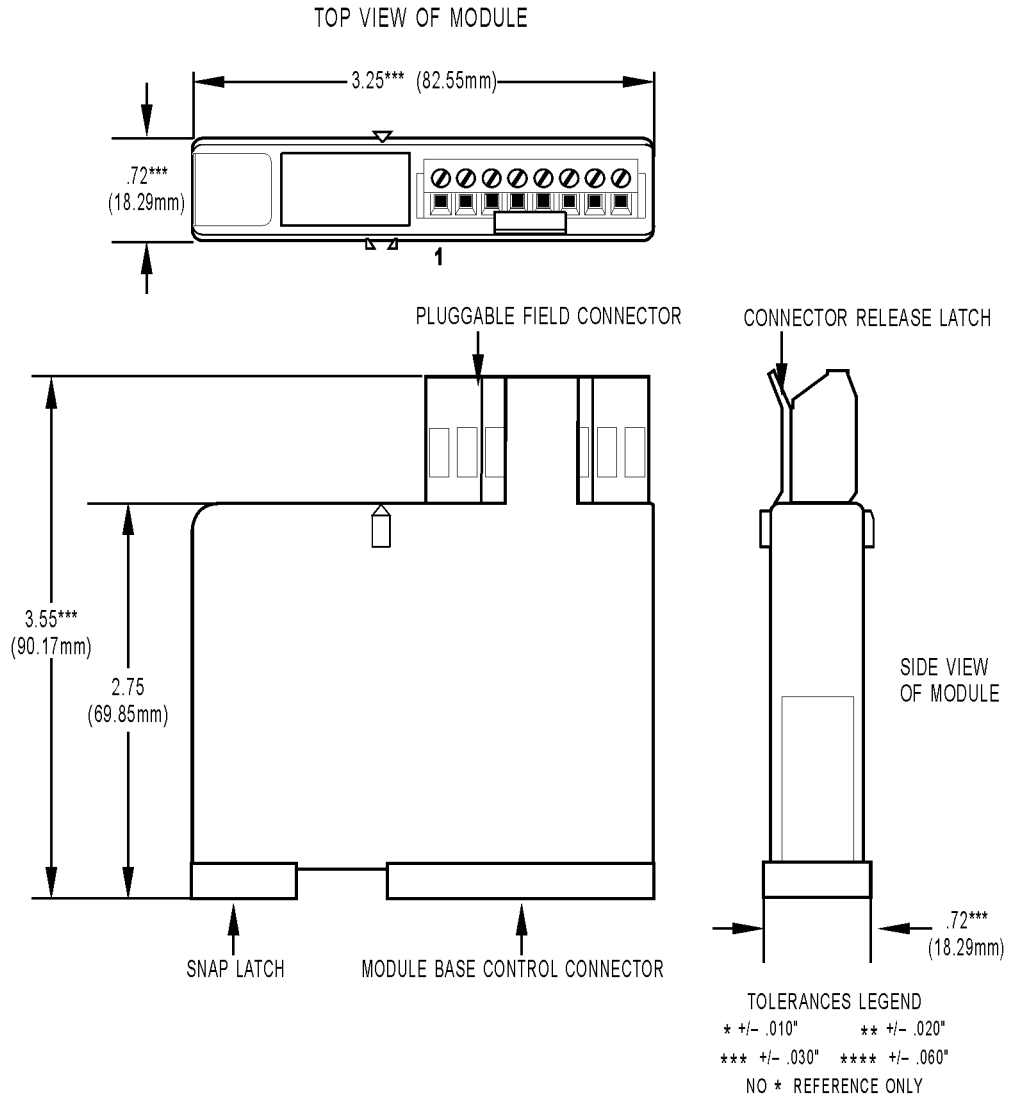

## All SNAP Output Models Except MA and Mechanical Relays

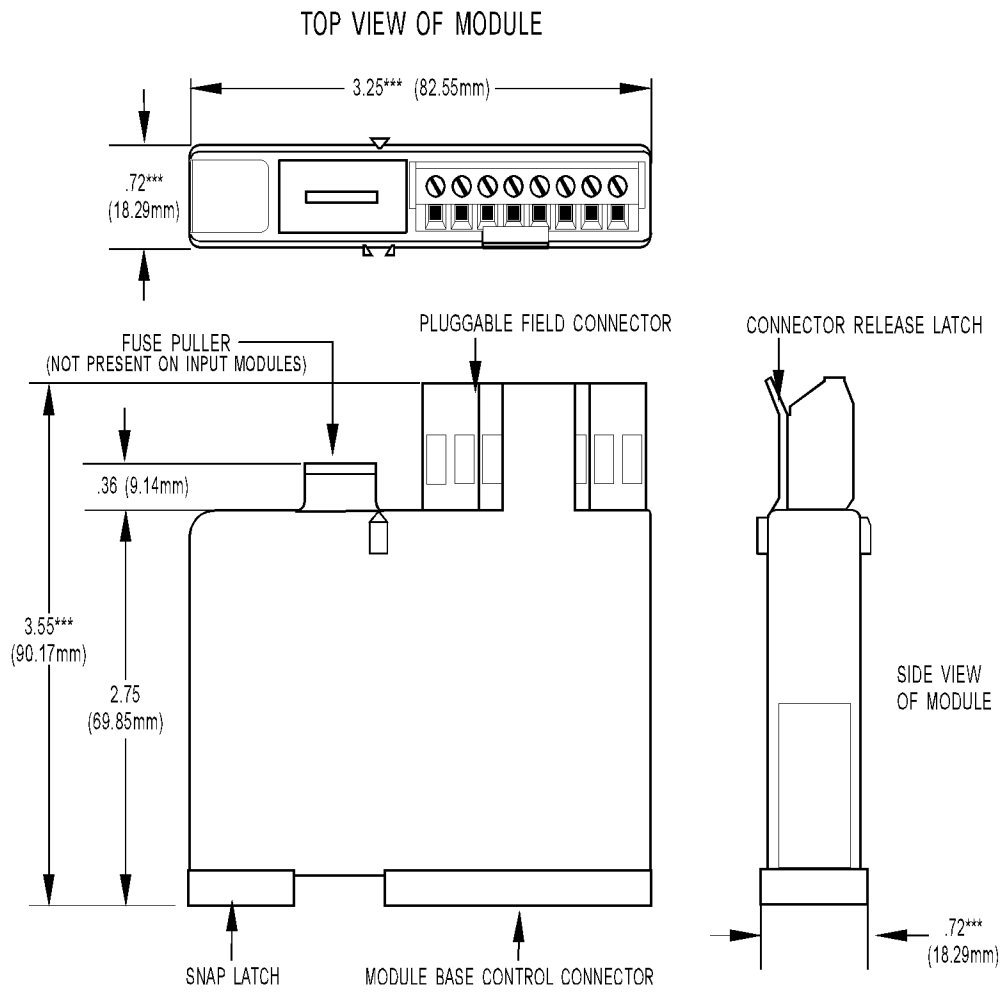

**TOLERANCES LEGEND**  
 \* +/- .010"      \*\* +/- .020"  
 \*\*\* +/- .030"    \*\*\*\* +/- .060"  
 NO \* REFERENCE ONLY

## All MA Models

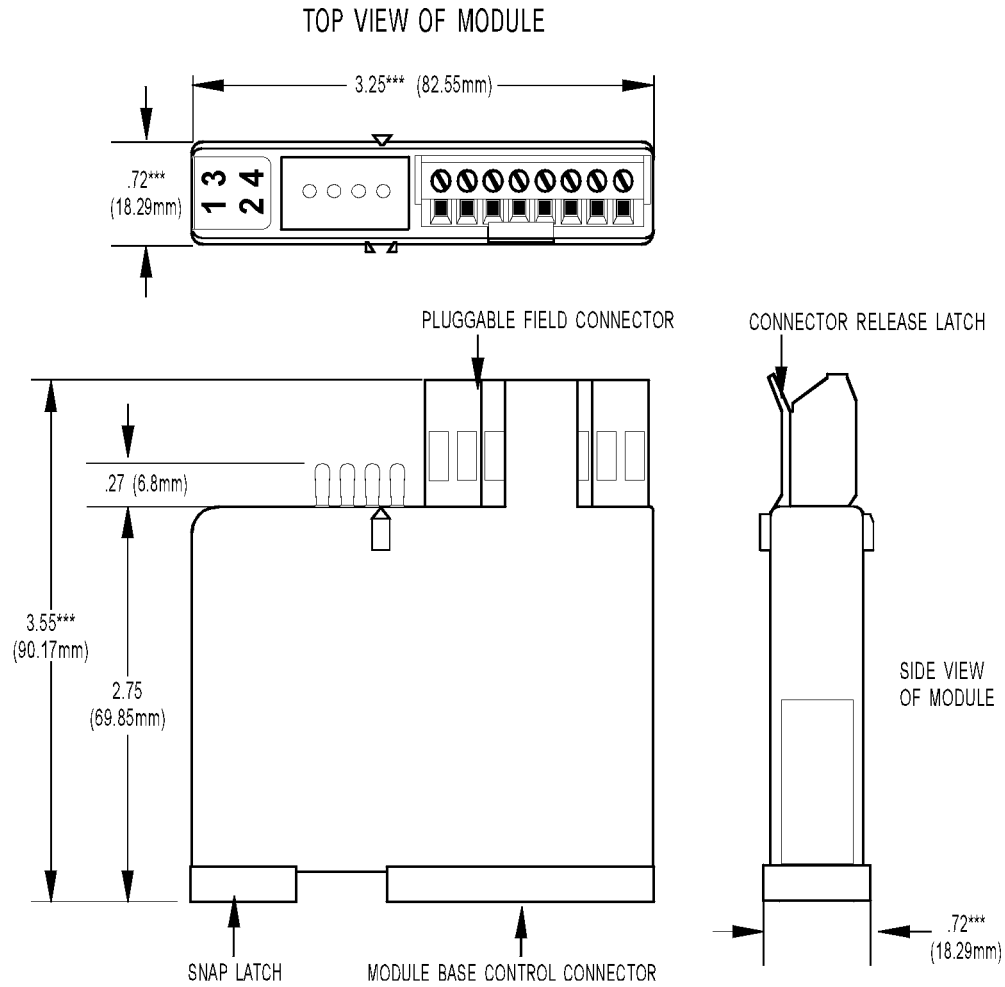

**TOLERANCES LEGEND**

- \* +/- .010"
- \*\* +/- .020"
- \*\*\* +/- .030"
- \*\*\*\* +/- .060"
- NO \* REFERENCE ONLY

## All SNAP Mechanical Power Relay Output Modules

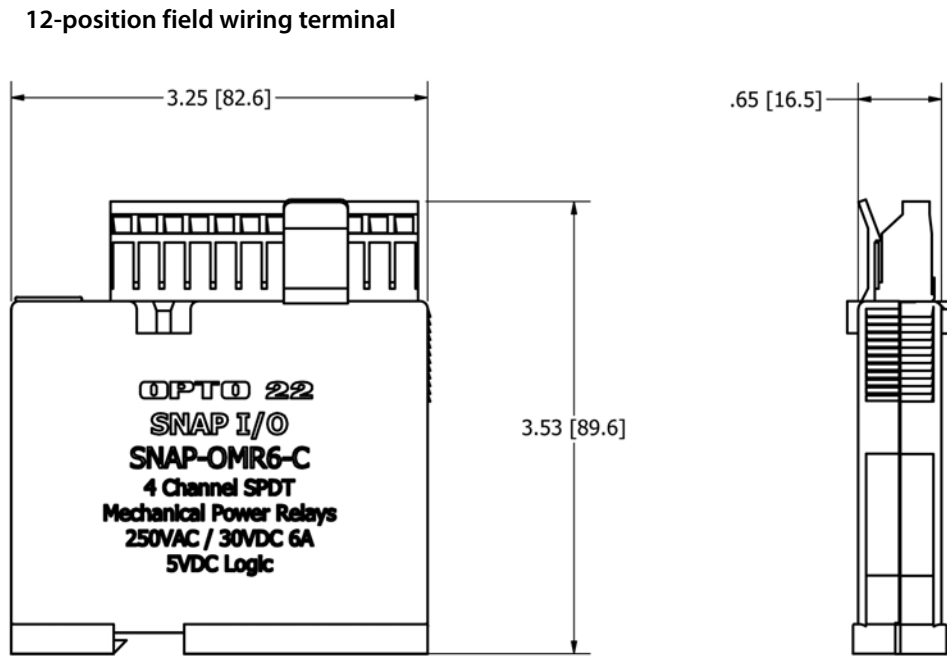

## Bottom, All Models

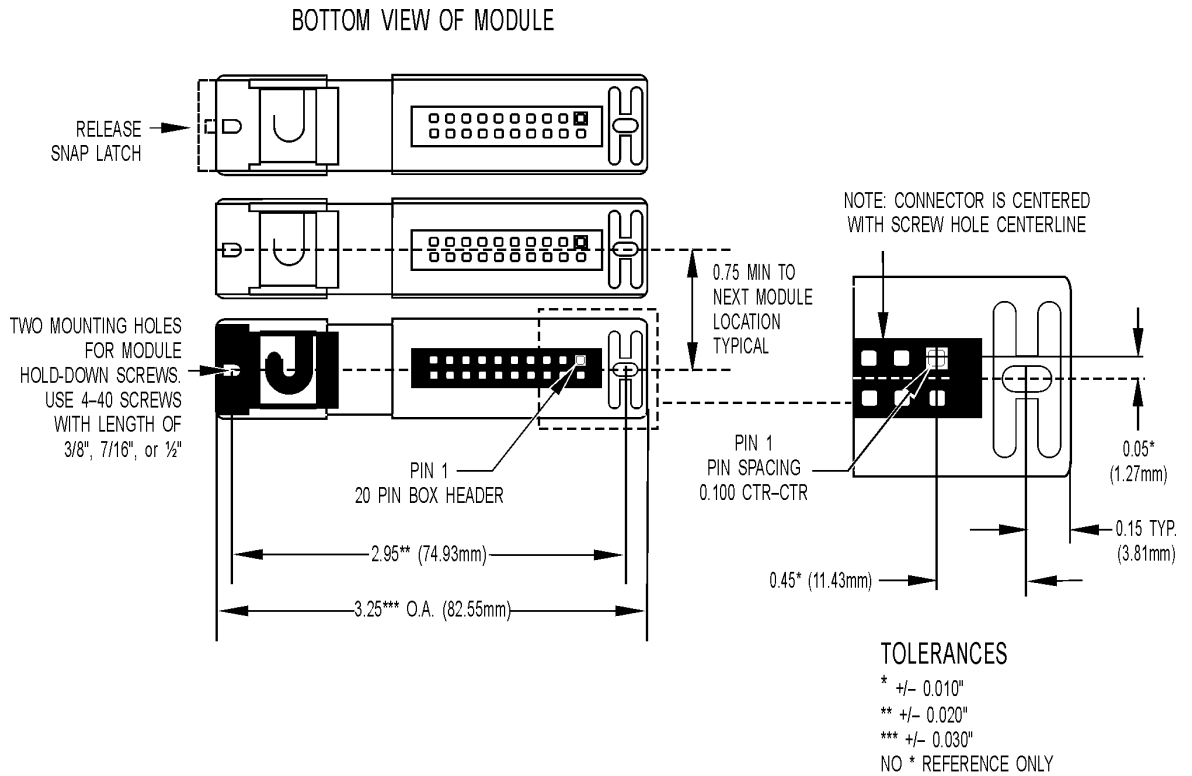

**IMPORTANT:** The mounting rack connector has 24 pins; the module connector has 20 pins. The extra pins on the mounting rack connector prevent misalignment of the module during installation.



# 4: Digital I/O Accessories

## Overview of Accessories

Accessories for Digital I/O for Raspberry Pi include the following:

- Power Supplies—see below.
- Fuses—see [page 47](#).
- Jumper straps—see [page 50](#).

## Power Supplies

You can power the rack from the Pi or power the Pi from the rack. We recommend powering the Pi from the rack, to ensure sufficient, consistent, and reliable power to all devices connected to the Pi. Choose your power supply based on your system: G4 below, or SNAP on [page 48](#).

### Power Supplies for G4

For G4 systems, the following industrial power supplies are available to power the Pi, rack, and I/O modules.

Choose the one you need based on your input voltage:

Input voltage	Output Current	Part number	Comments
120 VAC	0.5 A	<a href="#">PBSA</a>	Screws to threaded contacts on the mounting rack; fits conveniently underneath the Carrier Board
220 VAC	0.5 A	<a href="#">PBSB</a>	
12/24 VDC	1.5 A	<a href="#">PBSC</a>	



**USB peripherals:** If you are using USB-powered peripherals attached to the Pi (like hard drives, displays, or WiFi dongles) you require a larger power supply that puts out more current. We recommend a 5 V power supply rated 2.5 A to 5 A, connected to the rack power terminals.

If you are powering through the Pi, follow the Raspberry Pi Project's 2.5 A recommendation.

Note that if you're using peripherals, you'll also need to replace the mounting rack's 1 A fuse with a 5 A fuse (included with the Digital I/O Carrier Board). See ["Fuses" on page 49](#).

## Power Supplies for SNAP

For a SNAP system for Raspberry Pi, you'll need a 5 V power supply connected to the SNAP-D4M rack's power terminals. To determine the size supply you need, fill out the following worksheet. For help on your Pi's power requirements, see the [Pi FAQ](#).

Item	Quantity	X Power Requirements (Amps)	Total Power Required (Amps)
Raspberry Pi (check your model's specs)	1		
USB peripherals (total)	---		
SNAP-D4M mounting rack	1	0.20	0.20
SNAP-IDC5-SW SNAP-IDC5-SW-NC		0.20	
SNAP-OMR6-C SNAP-OMR6T-C		0.16	
All other SNAP digital input or output modules		0.05	
<b>Total current needed for system:</b>			

Here's an example of how you'd use the worksheet. Suppose you have:

- Raspberry Pi 3 model B
- Peripherals plugged into the Pi's USB ports that require 1 A total current
- Two SNAP-IDC5-SW, one SNAP-OMR6-C, and one SNAP-OAC5-I on the rack

You'd complete the worksheet like this:

Item	Quantity	X Power Requirements (Amps)	Total Power Required (Amps)
Raspberry Pi (check your model's specs)	1	<b>1.34</b>	<b>1.34</b>
USB peripherals (total)	---	<b>1.00</b>	<b>1.00</b>
SNAP-D4M mounting rack	1	0.20	0.20
SNAP-IDC5-SW SNAP-IDC5-SW-NC	<b>2</b>	0.20	<b>0.40</b>
SNAP-OMR6-C SNAP-OMR6T-C	<b>1</b>	0.16	<b>0.16</b>
All other SNAP digital input or output modules	<b>1</b>	0.05	<b>0.05</b>
<b>Total current needed for system:</b>			<b>3.15 A</b>

**IMPORTANT:** The SNAP-D4M mounting rack ships with a 1 A fuse. If you're using peripherals, replace it with a 4 A fuse. One of these is included with the Digital I/O Carrier Board for convenience. Also see "Fuses" on page 49.

## Fuses

Your Digital I/O System for Raspberry Pi includes a fuse on the mounting rack and fuses on most G4 and SNAP output modules.

### G4 Fuses

**G4 mounting rack fuse**—The G4PB8H and G4PB16H mounting racks come equipped with a 1A fuse, which is sufficient for the Raspberry Pi, rack, and I/O modules. However, if you're using USB-powered peripherals (especially USB-WiFi dongles, displays, and hard drives), the 1 A fuse is not sufficient.

If you are using USB peripherals, replace the 1 A fuse in the rack with a 5 A fuse. For your convenience a compatible 5 A fuse is shipped with the OPTO-P1-40P Carrier Board.

**G4 output module fuse**—A 4-amp fuse is mounted on the top of most modules. Each mounting rack ships with one spare module fuse. Additional fuses can be ordered from Opto 22 or directly from Wickmann.

#### G4 Fuse part numbers:

Description	Part Number
1 amp fuses for G4PB8H or G4PB16H mounting racks (10 pack)	FUSE01B
5 amp fuses for G4PB8H or G4PB16H mounting racks (10 pack)	FUSE05B
4 amp fuses for G4 output modules (10 pack) (Not used for G4SWOUT modules)	FUSEG4B



### SNAP Fuses

**SNAP mounting rack fuse**—The SNAP-D4M comes equipped with a 1A fuse. If you're using USB peripherals with your Raspberry Pi, the 1 A fuse is not sufficient. Replace it with a 4A fuse. For convenience, a compatible 4 A fuse is shipped with the OPTO-P1-40P Carrier Board.

**SNAP output module fuse**—A 4 A fuse is located on the top of most modules, with a small handle to remove it. Replacement fuses can be ordered from Opto 22 or directly from Wickmann.

Description	Part Number
4 amp fuses for SNAP racks and output modules (25 pack)	SNAP-FUSE4B



## Jumper Straps

Jumper straps are used to simplify wiring in applications that require a common connection between I/O module positions.

### G4 Jumper Strap

The [G4STRAPB](#) (package of 10) can be used on both the G4PB8H and G4PB16H I/O mounting racks. Each jumper strap has an insulated coating and can be cut to size.



#### Dimensions:

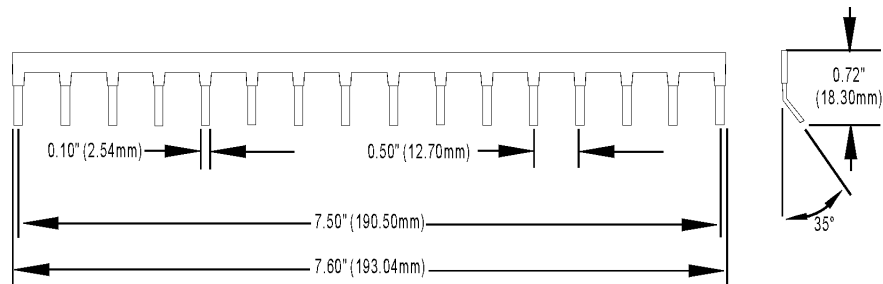

### SNAP Jumper Straps

For SNAP modules, choose the strap that fits your module. To connect jumper straps on multiple modules, use the SNAP Wirestrap.

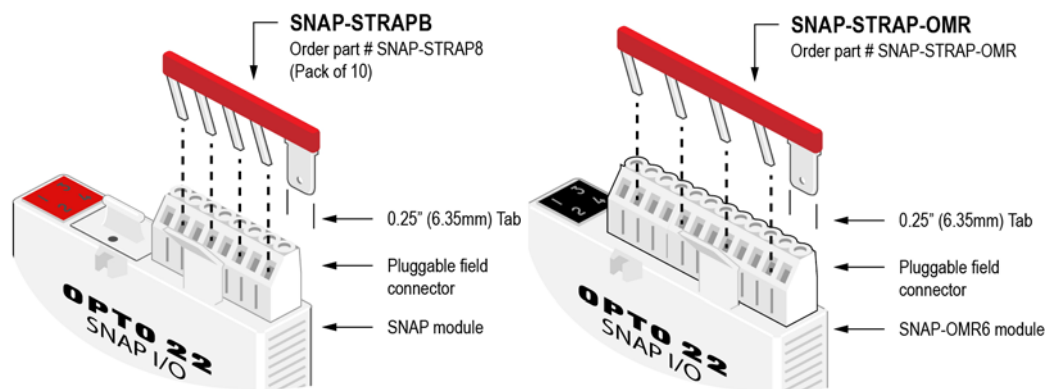

SNAP-STRAPB works with 8-position field connectors on many SNAP I/O modules.

SNAP-STRAP-OMR works with 12-position gray field connectors on SNAP-OMR6 modules.

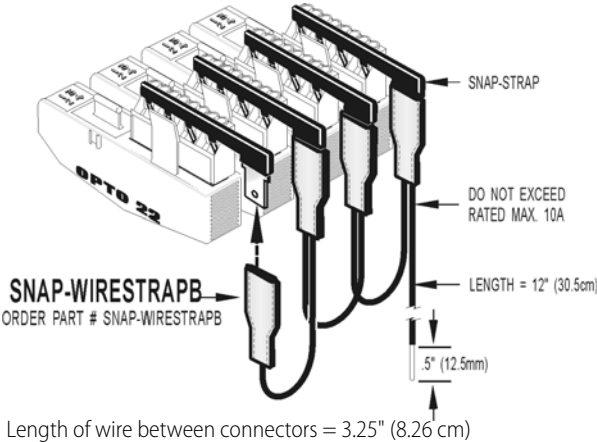

Description	Part Number
Pack of 10 jumper straps for digital SNAP I/O modules	<a href="#">SNAP-STRAPB</a>
Jumper strap for SNAP-OMR6 modules	<a href="#">SNAP-STRAP-OMR</a>
Pack of 10 jumper connectors for digital SNAP I/O modules	<a href="#">SNAP-WIRESTRAPB</a>



# 5: Reading and Writing

## Overview

It's easy to read and write to Opto 22 I/O points using your favorite Pi-supported language—Python, Node-RED, Pi Terminal, Pi Filesystem GPIO, or many others.

Visit [developer.opto22.com](http://developer.opto22.com) for code samples and tips for using your Pi to read and write to Opto 22 I/O modules.

**IMPORTANT:** Opto 22 I/O modules use negative true logic; that is, a zero bit means On and a 1 bit means Off. When reading and writing to I/O points, remember that 0 is On and 1 is Off.

## Mapping: GPIO Pins to SNAP I/O Modules

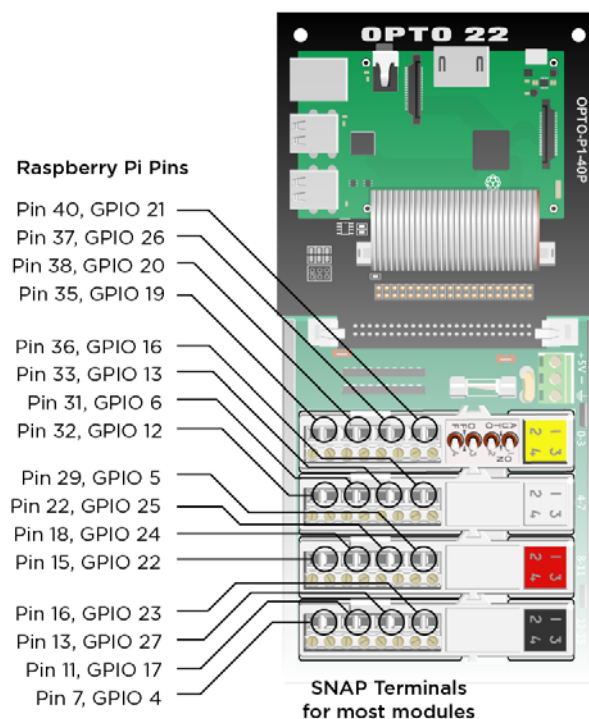

## Mapping: GPIO Pins to G4 Modules

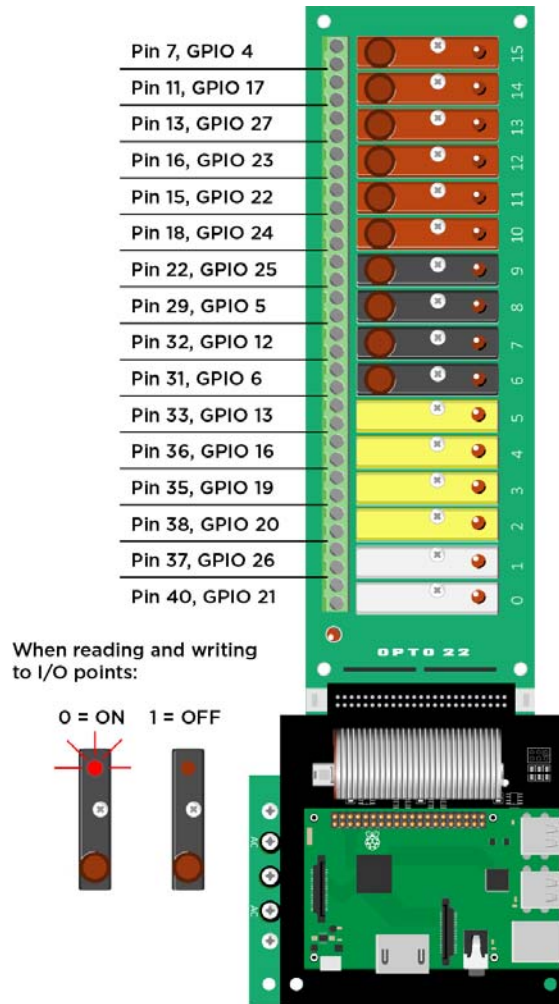

## Mapping Overlay for Raspberry Pi

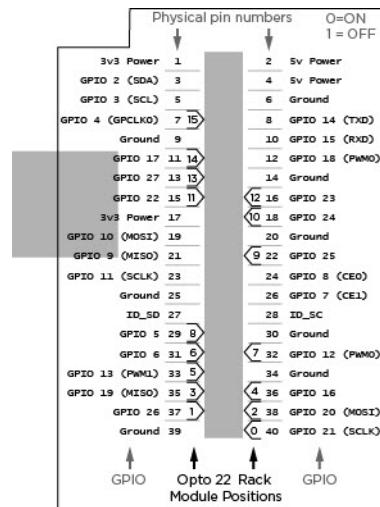

Place this overlay over your Pi's GPIO pins for a handy mapping reference. You can download the template from [developer.opto22.com](http://developer.opto22.com).